

Installation, Operation and Maintenance Manual

# WKM<sup>®</sup> DYNASEAL<sup>®</sup> 370D4 BALL VALVE

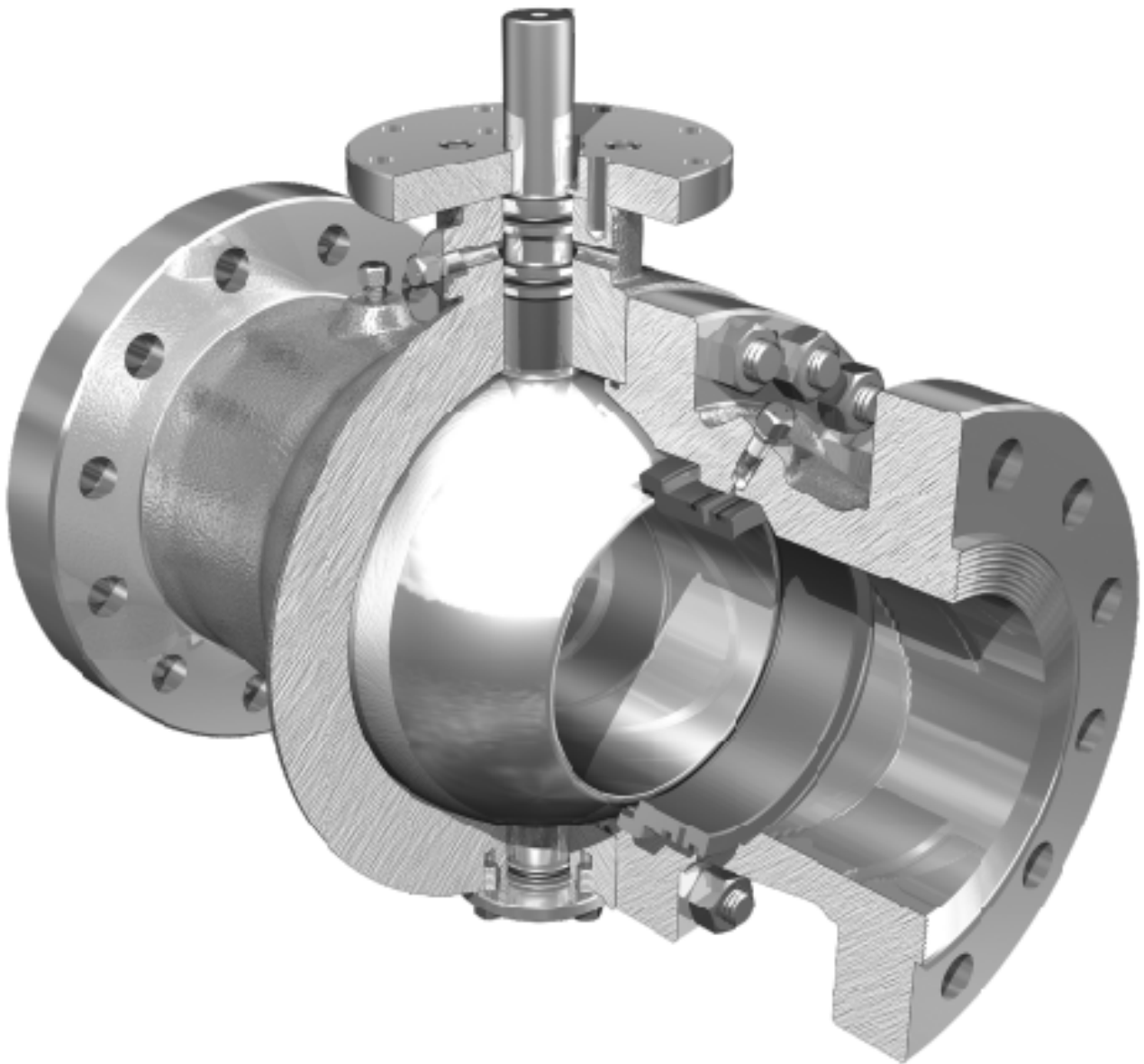

**WKM<sup>®</sup>**

**TABLE OF CONTENTS****WKM DYNASEAL 370D4 BALL VALVE**

Bill of Materials	
2" - 4" x 3" Class 150-900 370D4 .....	1
4" - 6" x 4" Class 150-900 370D4 .....	2
2" - 6" x 4" Class 1500-2500 370D4 .....	3
6" - 14" x 12" Class 150-900 370D4 .....	4
Nameplate Information .....	5
Scope .....	5
Storage .....	6
Installation .....	6
Operation .....	7
Routine Maintenance .....	10
Draining Valve and Releasing Body Pressure .....	10
Low Temperature Precautions .....	11
Maintaining Seals .....	11
Temporary Seal Restoration .....	12
Trouble Shooting .....	15

## Bill of Materials

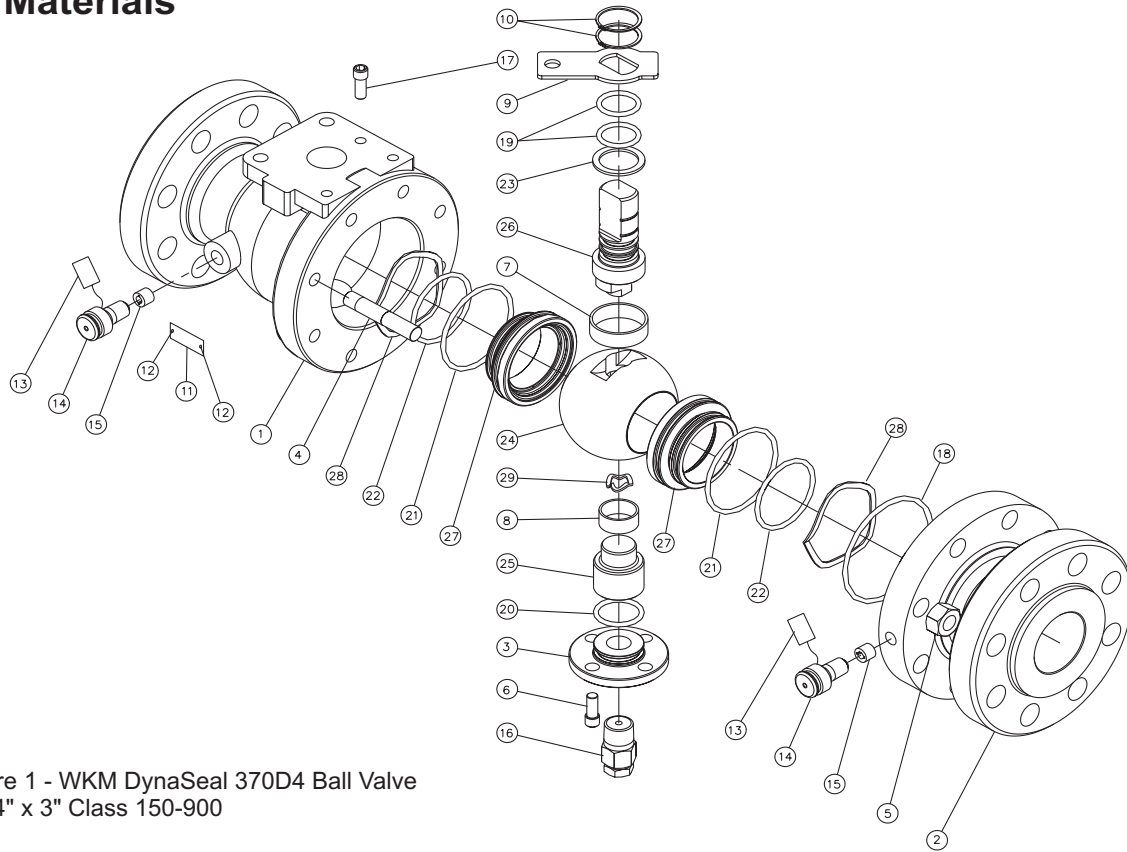
 Figure 1 - WKM DynaSeal 370D4 Ball Valve  
 2" - 4" x 3" Class 150-900

ITEM	QTY	DESCRIPTION	ITEM	QTY	DESCRIPTION
1.	1	Body	4	*	Hidden Check Valve
2.	1	Tailpiece	16.	1	1/2" Vent Fitting
3.	1	Lower Cover Plate	17.	1	Screw
1	*	Body Stud	18.	1	Tailpiece O-Ring
1	*	Body Nut	19.	2	Stem O-Ring
6.	4	Bolts (Lower Cover Plate)	20.	1	Trunnion O-Ring
7.	1	Bearings (Stem)	21.	2	Seat O-Ring
8.	1	Bearings (Trunnion)	5	*	Grease Seal Seat O-Ring
9.	1	Stop Plate	23.	1	Stem Seal
10.	2	Retaining Ring	24.	1	Ball
11.	1	Nameplate	25.	1	Trunnion
12.	2	Drive Screw	26.	1	Stem
2	*	Caution Tag	27.	2	Seat Assembly
3	*	Grease Fitting	28.	2	Seat Wave Spring
			29.	1	Wave Spring

1 Body Stud & Nut Qty. =

4 for 2" 150-300  
 8 for 2" 600-900 & 3" 150-900

2 Caution Tag =

0 for 2" - 3" 150-300\*  
 2 for 2" - 3" 600-900

3 Grease Fitting =

0 for 2" - 3" 150-300\*

4 Hidden Check Valve =

0 for 2" - 3" 150-300\*  
 2 for 2" - 3" 600-900

5 Grease Seal Seat O-Ring Qty. =

0 for 2" - 3" 150-300\*  
 2 for 2" - 3" 600-900

\* Option - If valves are purchased with this option, 2 each will be the quantity per valve.

## Bill of Materials

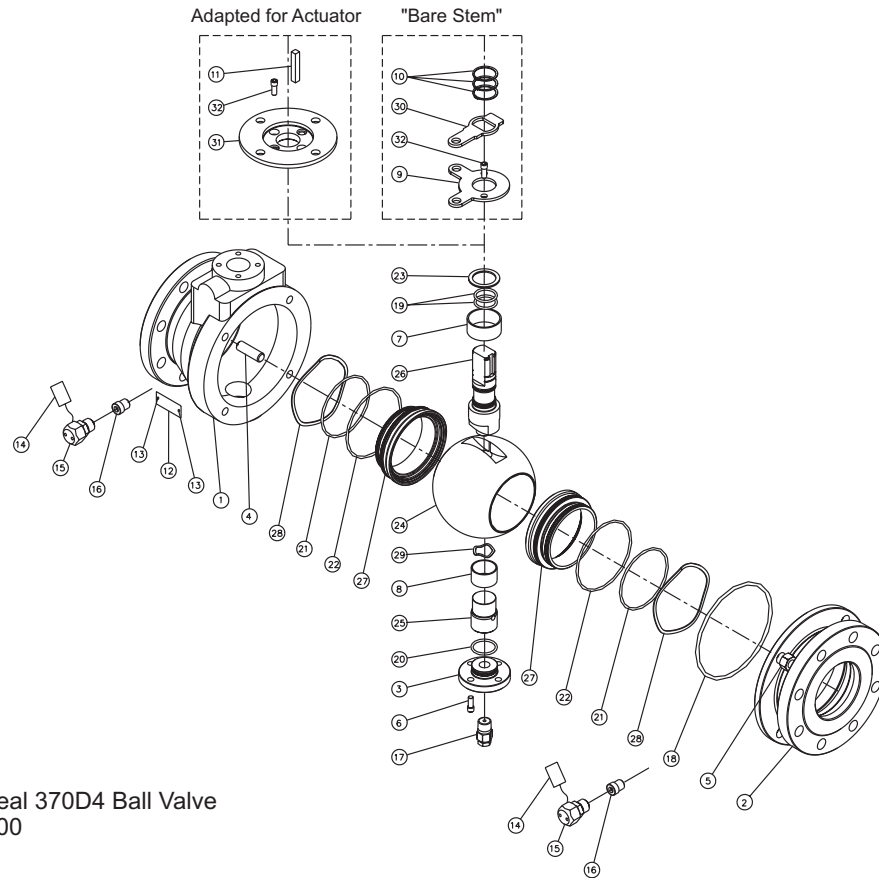
 Figure 2 - WKM DynaSeal 370D4 Ball Valve  
 4" - 6" x 4" Class 150-900

ITEM	QTY	DESCRIPTION	ITEM	QTY	DESCRIPTION
1.	1	Body	9	1	Drain Fitting
2.	1	Tailpiece	18.	1	Tailpiece O-Ring
3.	1	Lower Cover Plate	19.	2	Stem O-Ring
1	4.	* Body Stud	20.	1	Trunnion O-Ring
1	5.	* Body Nut	21.	2	Seat O-Ring
6.	4	Bolts (Lower Cover Plate)	5	22.	* Grease Seal Seat O-Ring
7.	1	Bearings (Stem)	23.	1	Stem Seal
8.	1	Bearings (Trunnion)	24.	1	Ball
6	9.	* Stop Plate	25.	1	Trunnion
6	10.	* Retaining Ring	26.	1	Stem
7	11.	* Key	27.	2	Seat Assembly
12.	1	Nameplate	28.	2	Seat Wave Spring
13.	2	Drive Screw	29.	1	Ground Wave Spring
2	14.	* Caution Tag	6	30.	* Lock Plate
3	15.	* Grease Fitting	7	31.	* Adapter Plate
4	16.	* Hidden Check Valve	8	32.	* Plate Bolts

1 Body Stud & Nut Qty. = 4 for 4" 150  
8 for 4" 600-900

2 Caution Tag Qty. = 0 for 150-300\*  
2 for 4" 600-900

3 Grease Fitting = 0 for 4" 150-300\*  
2 for 4" 600-900

4 Hidden Check Valve = 0 for 4" 150-300\*  
2 for 4" 600-900

5 Grease Seal Seat O-Ring Qty. = 0 for 4" 150-300  
2 for 4" 600-900

6 Parts required for "Bare Stem" valves = 1  
(0 required for valves adapted for Actuators)

7 Parts required for valves adapted for Actuators = 1  
(0 required for "Bare Stem" valves)

8 Plate Bolts 2 for valves with "Bare Stem"  
4 for valves adapted for Actuator

9 Drain Fitting 4" = 1/2"  
6" x 4" = 3/4"

\* Option - If valves are purchased with this option, 2 each will be the quantity per valve.

## Bill of Materials

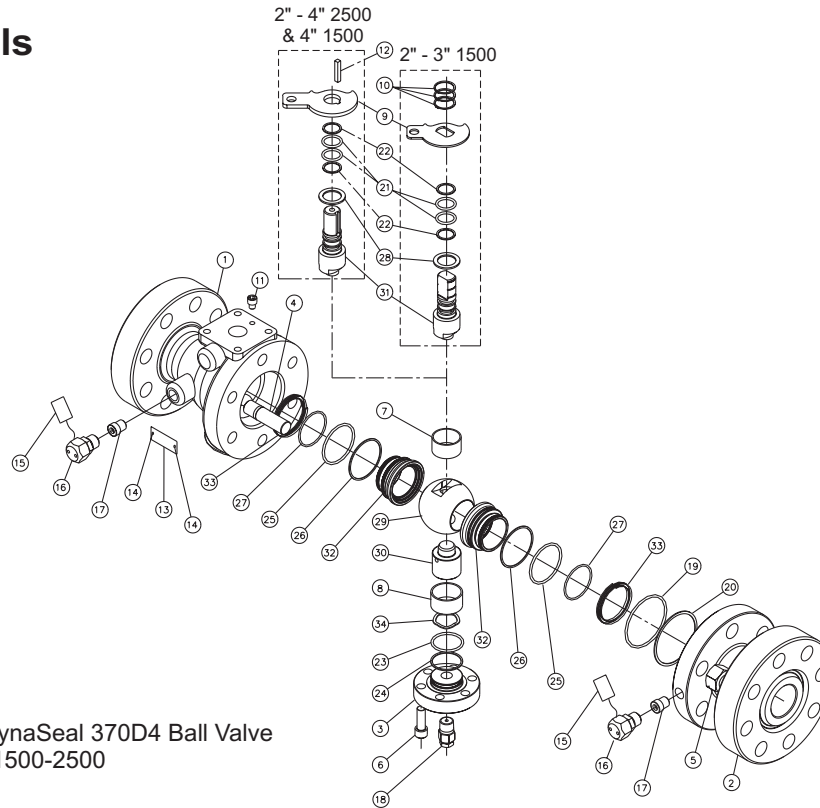
 Figure 3 - WKM DynaSeal 370D4 Ball Valve  
 2" - 6" x 4" Class 1500-2500

ITEM	QTY	DESCRIPTION	ITEM	QTY	DESCRIPTION
1.	1	Body	18.	1	Drain Fitting
2.	1	Tailpiece	19.	1	Tailpiece O-Ring
3.	1	Lower Cover Plate	20.	1	Tailpiece Backup Ring
1	*	Body Stud	21.	2	Stem O-Ring
1	*	Body Nut	22.	2	Stem Backup Ring
6.	6	Bolts (Lower Cover Plate)	23.	1	Trunnion O-Ring
7.	1	Bearings (Stem)	24.	1	Trunnion Back Up Ring
8.	1	Bearings (Trunnion)	25.	2	Seat O-Ring
9.	1	Stop Plate	26.	2	Seat Backup Ring
2	*	Retaining Ring	27.	*	Grease Seal Seat O-Ring
3	1	Stop	28.	1	Stem Seal
4	*	Key (Square)	29.	1	Ball
13.	1	Nameplate	30.	1	Trunnion
14.	2	Drive Screw	31.	1	Stem
15.	2	Caution Tag	32.	2	Seat Assembly
16.	2	Grease Fitting	33.	2	Seat Wave Spring
17.	2	Hidden Check Valve	34.	1	Ground Wave Spring

1 Body Stud & Nut Qty. =

6 for 2" 1500  
 8 for 2" 2500 & 3" - 4" 1500-2500  
 16 for 6" & 8" x 6" 1500

2 Retainer Ring =

3 for 2" 1500  
 0 for 2", 3", 4" 2500 & 4" 1500  
 2 for 3" 1500  
 0 for 6" & 8" x 6" 1500

3 Stop =

Socket Head Screw for 2" - 4" 150 & 2" - 3" 2500  
 Pin for 4" 2500, 6" & 8" x 6" 1500

4 Key, Square Qty. =

0 for 2" - 3" 1500  
 1 for 2" - 4" 2500 & 4" 1500, 6" & 8" x 6" 1500

5 Drain fitting

2" thru 4" = 1/2", 6" x 4" = 3/4"

\* Option - If valves are purchased with this option, 2 each will be the quantity per valve.

## Bill of Materials

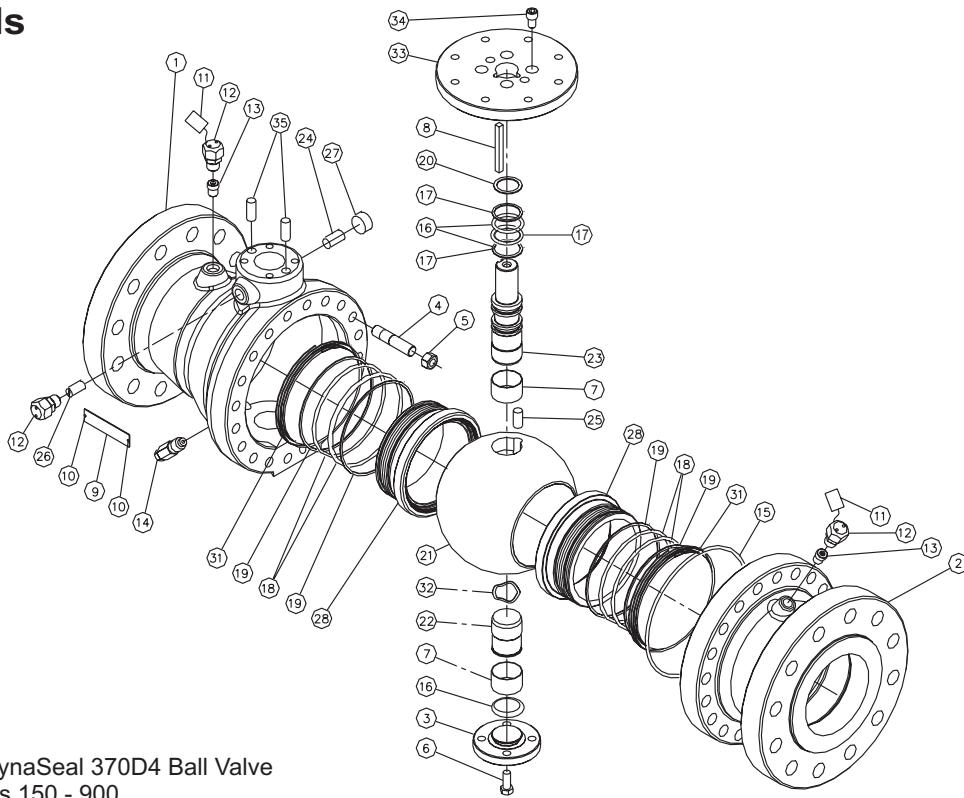
 Figure 4 - WKM DynaSeal 370D4 Ball Valve  
 6" - 14" x 12" Class 150 - 900

ITEM	QTY	DESCRIPTION	ITEM	QTY	DESCRIPTION
1.	1	Body	17.	2	Stem Backup Ring
2.	1	Tailpiece	18.	4	Seat O-Ring
3.	1	Lower Cover Plate	19.	4	Seat Backup Ring
1	*	Body Stud	20.	1	Stem Thrust Washer
1	*	Body Nut	21.	1	Ball
6.	4	Bolts (Lower Cover Plate)	22.	1	Trunnion
7.	2	Bearings (Trunnion & Stem)	23.	1	Stem
8.	1	Stem Key	2	*	Stem Retainer
9.	1	Nameplate	25.	1	Pin
10.	2	Drive Screw	3	*	Grease Fitting Stem Retainer
11.	2	Caution Tag for Check Valve	2	*	Pipe Plug
12.	3	1/2" Grease Fitting	28.	2	Seat Assembly
13.	2	1/2" Check Valve	31.	2	Seat Wave Spring
4	1	Drain Fitting	32.	1	Ground Wave Spring
15.	1	Tailpiece O-Ring	33.	1	Adapter Plate
16.	3	Stem & Trunnion O-Ring	34.	4	Bolts (Adapter Plate)
			35.	2	Pin (Adapter Plate)

1 Body Stud & Nut Qty. =

10 for 6" - 8" 150, 6" 300 & 10" 150  
 12 for 8" 900 & 12" 150  
 16 for 6" - 8" 900 & 10" - 12" 300  
 20 for 6" - 12" 600 & 10" - 12" 900

2 Stem Retainer & Pipe Plug Qty. =

0 for 6" - 12" 150, 6" - 12" 300 & 6" - 8" 600  
 1 for 10" - 12" 600 & 6" - 12" 900

3 Grease Fitting Retainer Qty. =

1 for 6" - 12" 150, 6" - 12" 300, 6" - 8" 600 & 8" - 10" 900  
 0 for 10" - 12" 600, 6" 900 & 12" 900

4 Drain Fitting

6" x 8" = 3/4"  
 10" and up = 1"

\* Option - If valves are purchased with this option, 2 each will be the quantity per valve.

## Nameplate Information

A nameplate is permanently affixed to each WKM DynaSeal 370D4 Ball Valve. The nameplate lists all the information necessary to identify the valve when making inquiries. Attaching the nameplate to the valve is the final step in a series of operations designed to provide you with quality service when ordering replacement parts, accessories, or making any inquiry about your valve's operation or maintenance.

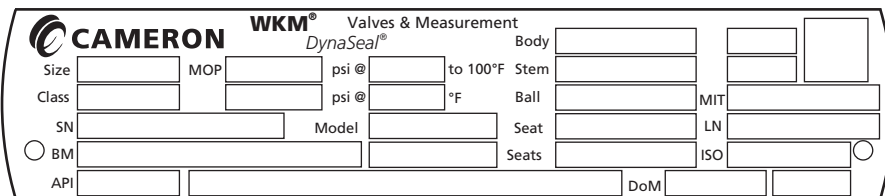

Figure 5 - WKM DynaSeal 370D4 Ball Valve Nameplate.

ITEM	STAMP
1.	Size: If full bore, size is nominal bore size. If reduced (regular or venturi port), size is nominal (end size) x bore through ball x nominal (end size).
2.	Class: Pressure classification.
3.*	SN: Valve's unique serial number.
4.	B/M: Number of valve assembly bill of material.
5.	CWP: Cold working pressure; the working pressure of the valve in psi @ 100°F.
6.	Body: Body material.
7.	Temp: Operating temperature range.
8.	Model: Valve's model designations.
9.	Stem: Stem material.
10.	Ball: Ball material.
11.	Seat: Seat material.
12.	Seals: Seal material.
13.	6D: For 6D valves with special lengths, end-to-end length is stamped here.
14.	DOM: Date of manufacture.
15.	MIT: Maximum impact temperature.
16.	LN: API license number.

\* Most important data for obtaining replacement parts.

## Scope

The WKM DynaSeal 370D4 End-Entry, Double Block and Bleed, trunnion ball valve is engineered for lengthy reliable performance. Manufactured in a variety of body and seal materials, this valve meets the requirements of the oil and gas pipeline industries, oil production industries as well as specialized pipeline and industrial process applications.

### Available Sizes:

	150	300	600	900	1500	2500		150	300	600	900	1500	2500
2"	x	x	x	x	x	x	8x6"	x	x	x	x	x	
3x2"			x	x			8"	x	x	x	x		
3"	x	x	x	x	x	x	10x8"	x	x	x	x		
4x3"			x	x			10"	x	x	x	x		
4"	x	x	x	x	x	x	12x10"	x	x	x	x		
6x4"	x	x	x	x	x	x	12"	x	x	x	x		
6"	x	x	x	x	x		14x12"	x	x	x	x		

## Storage

After WKM DynaSeal 370D4 Ball Valves are assembled and tested, the valves are left in the full open position, seats and bores are greased and end protectors are installed. These measures will provide protection for approximately six months. The following care should be taken when storing valves:

- 1) Make sure the valve end connection covers remain in place during storage.
- 2) If the valve does not have an operator and the valve will be stored outside, the exposed stem or the stem adapter should be covered to avoid accumulation of water and debris.

If long-term storage is required, the valve should be conditioned by following procedure X-150771-01 and ensure adequate end connection covers are in place. Request a copy of X-150771-01 from Cameron's Valves & Measurement group.

## Installation

DynaSeal 370D4 Ball Valves may be installed in any position with flow from either direction. However, for best service life there is a **preferred** horizontal position to maximize sealing and minimize the accumulation of sediment. In horizontal piping it is preferred to have the stem lying horizontal (i.e. stem toward the viewer) with pressure from the right. During operation, flow will act as a siphon and minimize retention of sediment.

When handling or installing a valve, keep the valve in the full open position whenever possible to prevent foreign object damage to the ball.

1. The valve should be lifted in such a way that the body supports the load.

---

**Caution: The journal and the end connection necks are suitable places to attach lifting slings. Never use handwheels or other protruding parts of the valve, gearbox or actuator not designated for this purpose.**

---

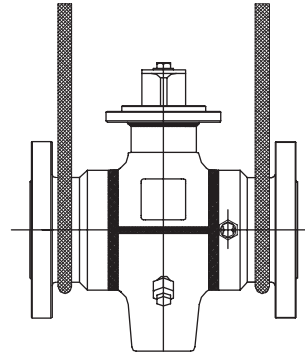

Figure 6 - Correct valve lifting using end connection necks.

2. If the valve is equipped with lifting lugs, these should be used for handling.
3. The end protector covers should be kept in place on the end connections during all handling. Remove only during final installation of the valve.

---

**Caution: During handling, protect the end connection faces and fittings against damage from the lifting devices. Failure to cover faces and fittings could cause damage to the valve.**

---

Flanged-End valves may be bolted into the line using two open or boxed end wrenches.

1. Threads of flanged bolts and nuts should be lubricated to obtain proper loading of bolts.
2. Finger-tighten all nuts first.
3. When tightening bolts, use the crisscross method and torque each bolt to ASME or gasket manufacturer's specification.

Butt Welded Ends - To prevent seat and seal damage due to excessive heat or weld slag, the following procedure is recommended for welding DynaSeal 370D4 Ball Valves into a line:

1. Use solvent to clean grease or rust inhibitor from the ball and/or bore of the valve.
2. Electric welding equipment is preferred for all installations. However, if only oxygen-acetylene welding equipment is available, extreme caution should be taken regarding excess welding temperature.
3. Weld with the ball in the "Full Open" position.
4. Make sure temperature of the body/seat area does not exceed 250°F. (Check with Tempil stick).

5. Avoid rapid application of excess welding material. Weld each end of valve with a continuous bead using a 1/8" maximum diameter electric welding rod.
6. Thoroughly clean (by pigging and/or flushing) weld slag from the valve bore and line before turning ball to the closed position.

If the ball must remain in the closed position during the installation of the valve, coat the exposed surfaces of the ball with grease. This will protect the ball from damage due to weld splatter.

---

**Caution: A weld end valve without pup pipes should never be installed in the closed position.**

---

After the installation (of the valve in line) is complete and any desired testing is finished, the valve should be thoroughly drained to eliminate water or other test fluid from the body. (See Draining Valve and Releasing Body Pressure, page 13). If the valve is equipped with seat injection, the seats should be charged with valve lubricant to displace any residual moisture in the seal areas. (See Maintaining Seals, page 14)

---

**Caution: Do not leave the valve in a partially open position for an extended period of time.**

---

---

## Hydrostatic Testing

When WKM DynaSeal 370D4 Ball Valves are installed in a piping system that requires hydrostatic testing of the adjoining pipe, follow these procedures to minimize any damage that could occur to the sealing surface and seat seals inside the valve.

---

**Caution: Ensure that all test fluid contains corrosion inhibitors and these are compatible with the valve seat and seal material.**

---

1. The valve should be in the fully open position when the injection of test fluid begins. This will allow any pipeline debris to be flushed through the valve bore and out of the piping.
2. Once the piping system has been purged of debris and the system has been filled completely with the test fluid, the ball should be placed in the partially open position (approx-

mately 10° from the fully open position). This allows test fluid into the body cavity of the valve.

3. The valve is now ready to be hydrostatic pressure tested.
4. Upon completion of hydrostatic testing, the valve should be returned to the fully open position before removing the test fluid from the piping system. The test fluid in the body cavity can be drained through the body drain port located on the lower portion of the valve body. (See Draining Valve and Releasing Body Pressure, page 13)
5. Close the valve body bleed fitting and return the valve to required operating position, either fully open or fully closed.
6. If the valve is equipped with seat injection fittings, the valve seat pockets should be filled with an approved valve lubricant to displace any test fluid from behind the seats. (See Maintaining Seals, page 14)

## Mounting a Gear/Actuator

To mount a gear on a valve, use the following as guidelines. **Note:** The following information is for typical gear designs. Specific instructions for each design should be obtained from gear manufacturer.

1. Make sure the valve is in the fully open or closed position and position the actuator to match.
2. Depending on the valve stem and the gear mounting kit, it is possible that the actuator may be installed in multiple positions. If this is the case, determine where the customer desires the handwheel and install it accordingly. (A thin layer of anti-seize or grease on the valve stem is recommended.)
3. Once the operator is mounted, secure it with the appropriate bolts. If the bolt holes do not line up, slightly operate to the open or closed to match the mounting flange.
4. It is now necessary to set the operator stops as outlined in the following section.

## Setting Stops.

DynaSeal 370D4 Ball Valves do not have stops when mounting a gear or actuator on 2" through 4x3" class 150 through 2500 and 4" through 6x4" class 1500 and 2500. The stop plate (item 9) and Stop (item 17, class 150 – 900 /item 11, class 1500 – 2500) are removed before mounting an operator. The 4" and 6x4" class 150 through 900 also has no manual stop plate when specified for actuation. An adapter plate (item 31) is provided. All other DynaSeal 370D4 Ball Valves, 6" and larger, are equipped with a slot in the Adapter Plate (item 33 of figure 4). The key on the valve stem overlaps this slot and will indicate the stem location for full open and full closed.

---

**Caution:** This slot is not designed to absorb the full operating torque of the valve. It is provided as a positive location to set the gear/actuator stops. Apply only enough torque or power to move the ball and stem to the open or closed position with no differential pressure across the valve.

---

1. Make sure that operating the valve to the fully open and fully closed position will not disrupt current operation of the line.
2. Loosen the open and closed stop screw locknuts on the operator.
3. Partially back out the stop screw on the open side of the operator.
4. Operate the valve to the full open position. This is indicated when the flats on the stem are in line with the bore (2" through 6x4") or when the key touches the slot in the adapter plate (6" through 14x12"). If the ball stops short of the full open position, additionally back out the open stop screw on the operator and move the ball to the full open position.
5. Turn the open stop screw clockwise until it stops, then tighten the locknut.
6. To set the closed stop, partially back out the stop screw on the close side of the operator.
7. Operate the valve to the full close position. This is indicated when the flats on the stem are perpendicular to the bore (2" through 6x4") or when the key touches the slot in the adapter plate and the key is perpendicular to the bore (6" through 14x12"). If the ball stops short of the full close position, additionally back out the closed stop screw and move the valve to the full close position.
8. Turn the close stop screw clockwise until it stops, then tighten the locknut.
9. After mounting the operator, operate the valve three times to check for proper movement.
10. Perform a seat seal test on each side of the valve.

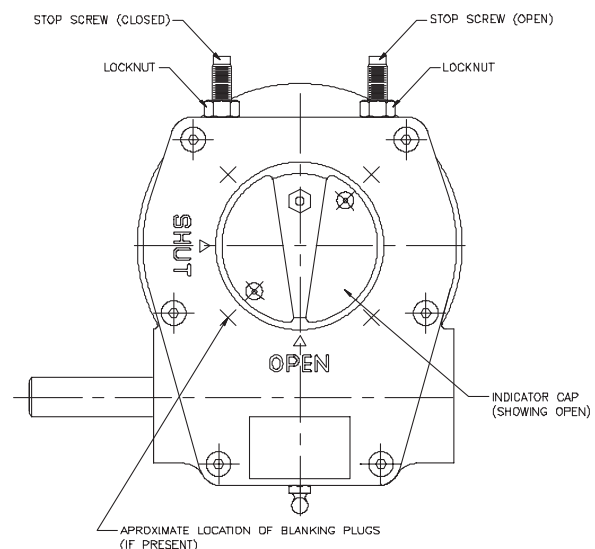

Figure 7 - Typical gear box with stops

## Operation

DynaSeal 370D4 Ball Valves operate from full open to fully closed by a 90 degree turn of the handle. The handle aligned with the pipe always means the valve is open. The handle perpendicular to the pipe means the valve is closed. Additionally, for stems with keys the bore of the ball is in line with the key and for stems with two flats, double D configuration, the bore of the ball is in line with the flats.

Worm gear operators, available on all size valves, have an arrow on the top of the operator unit that indicates the "OPEN - CLOSE" position of the ball. The open and closed position of the valve is set or controlled by stops on the worm gear unit. Facing the handwheel, rotating the handwheel clockwise closes the valve while counter-clockwise opens the valve. The handwheel should be turned until it contacts an open stop or closed stop depending on the desired valve position. Note: Handwheel movement in these directions is an accepted industry practice for opening and closing any valve with a worm gear operator.

DynaSeal 370D4 Ball Valves may be power actuated. Pneumatic and hydraulic actuators, whether of the fail-open, fail-close, or fail-last position type, have "OPEN - CLOSED" indicators on the top of each unit. On a pneumatic actuator, make sure filters and lubricators (if recommended by the actuator manufacturer) are installed prior to the valve and actuator installation. Should any maintenance be necessary, obtain the part number from the unit's nameplate and contact Cameron's Valves & Measurement group or the nearest representative.

The body cavity of a DynaSeal 370D4 Ball Valve can be blown down or drained through the body

vent port when the valve is closed with pressure on each side of the ball. Take the following steps when double block and bleeding the valve.

---

**Warning: Make sure proper safety garments are worn and follow all customer safety procedures. Failure to do so could injure you or others.**

---

1. Note the location of the body vent fitting. Check the direction the hole on the side of the vent fitting. Any debris in the valve or fitting will be exhausted at a high velocity.

---

**Warning: To avoid possibly being struck by liquid or foreign solid matter, position yourself so the hole of the bleed fitting is pointing safely away from you and back-up the vent body so only the hex head on the top of the fitting is unscrewed.**

---

2. With the valve fully closed, open the body vent fitting all the way. A backup wrench on the body of the fitting should be used to prevent accidental loosening and removal of the body vent fitting.

For additional information on venting see Draining Valve and Releasing Body Pressure, page 13

---

**Warning: Never try to block and bleed the valve in the partially open position.**

---

## Routine Maintenance

Under normal working conditions, the WKM DynaSeal 370D4 Ball Valve is designed for lengthy, reliable service. The following recommended practices and procedures will ensure optimum performance of your valve.

**Caution: Verify compatibility of any sealant, lubricant, or anti-freeze with the trim of the valve and product in the line.**

### Types of Fittings:

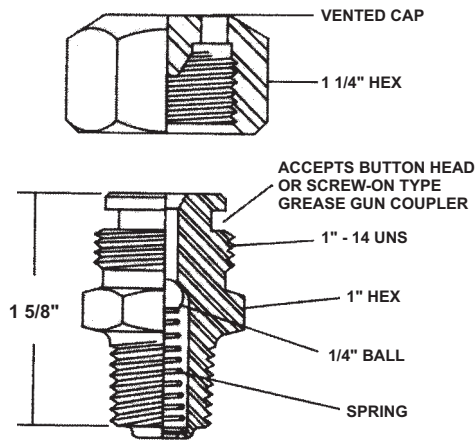

Figure 8 - Typical Injection Fitting

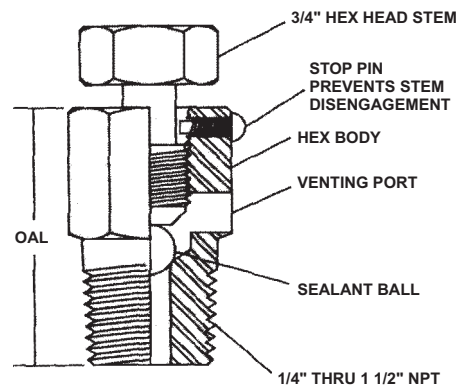

Figure 9 - Vent or Bleed Fitting

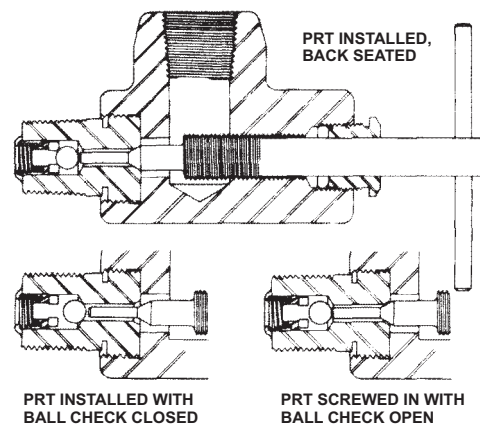

Figure 10 - Pressure Releasing Tool shown on Injection Fitting

## Draining Valve and Releasing Body Pressure

After lengthy service, there is a possibility of water, line scale, sediment or other foreign matter collecting in the lower body cavity. It is advisable to periodically drain the valve to discourage development of conditions that can possibly lead to valve damage or impair the operation of your valve. If draining is not regularly scheduled, it is strongly recommended to drain the valve at these times,

- 1) After hydrostatic testing
- 2) After cleaning the line
- 3) When valve can not be fully opened or closed (Foreign matter in the bottom of valve can not only prevent placing valve in a fully open or closed position, it can also cause permanent damage to the internal sealing surfaces.)

If valve is equipped with a vent or bleed fitting in the lower drain - to release body pressure or drain the valve, first place ball in closed position.

**Warning: To avoid possibly being struck by liquid or foreign solid matter, position yourself so relief port of vent or bleed (drain) fitting is pointing safely away from you and back-up the vent or bleed (drain) fitting so only the stinger is unscrewed.**

Carefully unscrew the stinger of the vent or bleed (drain) fitting to allow free flow of air, liquid or foreign solid matter to escape from body cavity. After body pressure is released or valve is drained, screw the stinger of the vent or bleed (drain) fitting back in to close the vent.

If valve is equipped with a grease fitting in the lower drain - a safety pressure releasing tool is

required to simplify the procedure of releasing body pressure or draining the valve. To release body pressure or to drain valve, first place ball in closed position.

---

**Warning: To avoid possibly being struck by liquid or foreign solid matter, position yourself so the outlet port of grease fitting is pointing safely away from you and back-up the grease fitting so only the safety cap is unscrewed.**

---

Carefully remove the safety cap of the lower drain grease fitting. Back out the stinger of the pressure releasing tool until it stops. Install the safety pressure releasing tool onto the uncapped grease fitting. Carefully screw the stinger of the releasing tool in - (until the ball check in the grease fitting is pushed off its seat). This will allow the valve to drain or to release body pressure. After completion, back out the stinger of the pressure releasing tool to allow the ball check in the grease fitting to reseal and permit easy removal of the pressure releasing tool. Replace safety cap on the lower drain grease fitting.

## Low Temperature Precautions

Prior to exposure to freezing temperatures it is highly recommended the valve be drained. Water that may be trapped in the body cavity could freeze and impair the operation of the valve or damage the valve. If the valve has a grease fitting in the lower drain, a sufficient amount of anti-freeze injected into the body cavity via the lower drain grease fitting will prevent accumulated water from freezing.

It is also advisable to inject a sufficient amount of valve lubricant into the grease fittings of valve and operator (if present) prior to extended cold temperature exposure.

Trapped water should be drained from stem extensions. Some stem extensions in the field are equipped with plastic plugs that can be removed to drain trapped water from the piped extension.

## Routine Seat Cleaning

The seat pocket area is the primary area where any valve can be affected by contaminants in the lines. To insure the seat's free movement, it is recommended that the valve seat pockets be cleaned routinely with an approved product. (The frequency of routine cleaning depends on the severity of service, but once a year is a good guideline.) The following cleaning procedure can be used on valves equipped with seat injection fittings.

1. Locate the seat injection fittings on the valve.
2. Make sure the grease gun / pump is in working order and loaded with the appropriate product.

---

**Warning: Backup the seat grease fitting so only the safety cap will be removed from the fitting. Carefully remove the safety cap from the seat grease fitting. NEVER remove the grease fitting when the valve is under pressure!**

---

3. Remove the safety vent cap from each grease fitting. Attach grease gun connection onto grease fitting and inject the full seat capacity of valve flush into each seat.
4. Make sure it is safe to operate the valve. Fully operate the valve three times.
5. Remove grease gun and replace safety vent caps on the grease fittings.

If additional cleaning is desired, inject the full seat capacity of valve flush into each seat and allow to soak for one to six hours. Inject the full capacity of valve flush again and operate the valve (if safe to do so) three times. This additional cleaning may help breakup buildup of contaminants.

## Maintaining Seals

The WKM DynaSeal 370D4 Ball Valve is Non-Lubricated. Unlike a typical plug valve the DynaSeal 370D4 does not depend upon the injection of sealant to activate seals. However,

occasionally injecting valve lubricant into seat and stem grease fittings will ensure optimum performance of the seat and stem seals and can help maintain long reliable service.

## Temporary Seal Restoration

If your valve seats or stem seal fail, normally it is possible to restore the seal or minimize any seat or stem leakage for an extended period of time (until it is convenient to remove the valve from service and replace the seals) with the injection of a sufficient amount of valve sealant into grease fitting (see chart for list of sealants). The valve must be equipped with the seat and/or stem injection feature.

WKM 103 Sealant is viscous grease with a consistency of peanut butter. It consists of synthetic oils, a suspending agent, friction-reducing filler, plastic and an antioxidant. WKM 103 Sealant may be used in valves with a temperature range of -50°F through 250°F. This sealant is suitable in lines transporting hydrocarbon liquids and gases where water, dilute acids, alkalies or salt solutions may be present as well as where sweet or sour produced gas with water or organic condensate, LPG and aqueous solutions are being transported. The gallon containers are for use with bucket-type high-pressure grease guns. Gun cartridges are poly bags sized to fit screw/prime high-pressure hand-guns.

Temporary seat seal restoration with the valve under line pressure for valves equipped with seat injection:

1. Fill the WKM High Pressure Grease Gun with valve sealant.
2. Place the valve in a fully closed position.

---

**Warning: Backup the seat grease fitting so only the safety cap will be removed from the fitting. Carefully remove the safety cap from the seat grease fitting. NEVER remove the grease fitting when the valve is under pressure!**

---

3. Remove safety vent cap from grease

fitting. Attach grease gun connection onto grease fitting and inject sealant.

4. Repeat process for the second seat grease fitting. If injection of the sealant is difficult, flush the valve seats and attempt to inject sealant again. Replace safety caps on seat grease fittings.

**Temporary seat seal restoration with the valve out of line: Note:** Before removing the valve from the line, all pressure must be relieved from the valve and line.

1. Fill the High Pressure Grease Gun with valve sealant.
2. Back up the seat grease fitting so only the cap will be removed from the fitting.
3. Carefully remove the safety cap from the seat grease fitting.
4. With the valve out of line, you should be able to view the bore interior.
5. Attach the High Pressure Grease Gun connection onto the grease fitting and inject sealant until sealant enters the valve bore.
6. Repeat process for the second seat grease fitting. Replace safety caps on seat grease fittings.
7. Excess sealant should be removed from the valve bore before valve is put back in service.

Temporary stem seal restoration for valves equipped with stem injection fittings:

1. Fill the WKM High Pressure Grease Gun with valve sealant.

---

**Warning: Backup the stem grease fitting so only the safety cap will be removed from the fitting.**

---

2. Carefully remove the safety cap from the stem grease fitting.
3. Attach grease gun connection onto grease fitting and inject sealant in stem grease fitting.
4. Replace safety cap on stem grease fitting.

<b>Sealant, Lubricant, and Flush Volumes for Valves with Individual Seat Injection</b>		
Nominal Size (Inches)	Sealant or Lubricant per Seat (Ounces)	Valve Flush per Seat (Ounces)
2	3	5
3	4	7
4	5	9
6	7	13
8	9	17
10	12	21
12	14	26

<b>WKM Sealant and Lubricant</b>			
Sealant No. 103	Part Number	Valve Lubricant 58G	Part Number
Gun Cartridge	K155812	Gun Cartridge	K154208
1 Gallon - 10 lbs.	K155849		
3 Gallon - 30 lbs.	K155853		
5 Gallon - 50 lbs.	K155857		
16 Gallon - 150 lbs.	K155866		
55 Gallon - 551 lbs.	K155869		

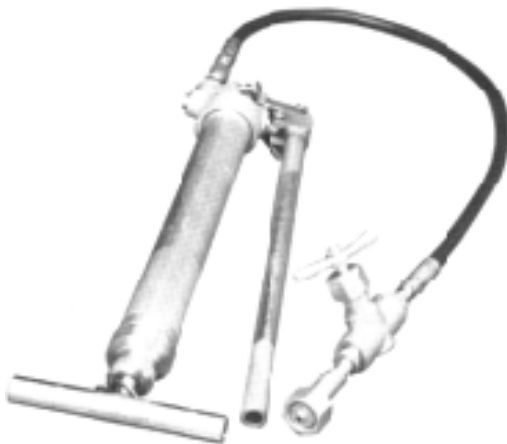

Figure 11 - Screw/Prime Hand Gun,  
Part Number 2122495-01  
Exact configuration may vary from photograph.



Figure 12 - Bucket-Type Gun,,  
Part Number K065189.  
Exact configuration may vary from photograph.



Figure 13 - Adapter Fitting,  
Part Number K296434

**Approved Flush / Sealant**

The following products are recommended by the cleaner / sealant manufacturers for the indicated service and condition. Contact your Cameron's Valves & Measurement group Representative for availability.

Service Conditions	Product	Cleaner / Sealant Manufacturer			
		WKM	Val-Tex	Sealweld	Lubchem
Natural Gas	Flush		Valve Flush	Valve Cleaner	Valve Saver
	Standard Valve Lubricant	WKM 58G	2000 Light Lube	EQ 80	Lubchem "50-400"
	Standard Sealant	WKM 103	80 bulk / 80-Hs stick	Total Lube 911	Everlast No.1
	Standard Low Temp		50 bulk / stick	Winterlub 7030	Everlast No.1 AG
	Severe Leak Sealant		80+PTFE bulk / Stick	Sealweld #5050	Formasil RS
Sour Gas	Flush		Valve Flush	Valve Cleaner	Valve Saver
	Standard Valve Lubricant	WKM 58G	2065 Light Lube	EQ 80	Lubchem "50-400"
	Standard Sealant	WKM 103	65 bulk / stick	Total Lube 911	Lubchem "50-400"
	Standard Low Temp		65 bulk / stick	Winterlub 7030	Lubchem "50-300"
	Severe Leak Sealant		80+PTFE bulk / Stick	Sealweld #5050	Formasil RS
Dry CO2	Flush		Valve Flush	Valve Cleaner	Valve Saver
	Standard Valve Lubricant	WKM 58G	2300 Silicone Light Lube	Sealweld Silicone Lubricant	Everlast WR
	Standard Sealant	WKM 103	302 bulk / stick	Sealweld Silicone Lubricant	Everlast WR
	Standard Low Temp		65 bulk / stick	Sealweld Silicone Lubricant	Everlast WR
	Severe Leak Sealant		80+PTFE bulk / Stick	Sealweld Silicone Sealant	Formasil CO2
Crude Oil	Flush		Valve Flush	Valve Cleaner	Valve Saver
	Standard Valve Lubricant	WKM 58G	2000 Light Lube	EQ 80	Lubchem "50-400"
	Standard Sealant	WKM 103	80 bulk / 80-Hs stick	Total Lube 911	Lubchem "50-400"
	Standard Low Temp		50 bulk / stick	Winterlub 7030	Lubchem "50-300"
	Severe Leak Sealant		80+PTFE bulk / Stick	Sealweld #5050	Formasil WR

## Valve Cleaner / Sealant Manufacturers

**Headquarters**

Cameron Valves & Measurement  
 3250 Briarpark Drive, Suite 300  
 Houston, TX 77042  
 281/499-8511  
 800/323-9160  
 281/261-3588 Fax  
 www.c-a-m.com

Val - Tex  
 Valves Incorporated of Texas  
 10600 Fallstone Rd.  
 Houston, TX 77099  
 281/530-484  
 800/627-9771

Sealweld  
 7240 Brittmore Suite 120  
 Houston, TX 77041  
 713/937-9222  
 800/237-0564

Lubchem Inc.  
 P.O. Box 2626  
 Spring, TX 77383  
 281/350-9600

## Troubleshooting

Trouble	Probable Cause	Remedy
The valve is hard to operate.	Actuator Unit	Refer to actuator maintenance manual or remove actuator cover and check stem adaptation and linkage for damage.
	Infrequent operation - lack of lubrication	Lubricate seats with valve lubricant and actuator with suitable industrial grease.
	Ice in valve operator	Apply heat or inject antifreeze solution into valve, but consult with authorized dealer prior to using remedy on operators.
	There is a build up in the seat area due to line contaminates.	Clean the seat area as outlined in Routine Seat Cleaning.
Ball is not properly aligned with bores of seats.	Restrictions in bore of valve or stop not set properly	Remove bore restrictions or check stop in worm gear actuator and/or actuator limit switches.
Erratic Operation	Damaged actuator unit	Replace broken or damaged parts
	Restriction of pneumatic actuator vent	Remove restriction
	Faulty power supply	Check power supply
	Infrequent operation - lack of lubrication	Lubricate seats with valve lubricant and actuator with suitable industrial grease
Valve is leaking between tailpiece and body.	Damaged O-Ring seal	Disassemble and replace O-Rings.
Leakage around valve stem	Damaged O-Ring seal	Inject valve sealant into stem fitting (if present) or replace stem O-Ring.
Valve will not fully close.	Ice in body of valve	Apply heat or inject antifreeze solution into body of valve. Drain periodically to eliminate water accumulation.
	Improper setting of actuator limit switches or stops in worm gear	Reset actuator limit switches or stops for proper closing
	Infrequent operation - lack of lubrication	Lubricate seats with valve lubricant and actuator with suitable industrial grease.
Grease fitting leaking	Damaged Fitting	Tighten safety cap or replace safety cap if damaged <b>WARNING:</b> Never remove entire grease fitting when valve is under pressure.
	Trash in fitting	Inject a small amount of cleaner into fitting to dislodge trash.

## Troubleshooting (continued)

<b>Trouble</b>	<b>Probable Cause</b>	<b>Remedy</b>
Valve will not seal.	Contamination around seat area due to service	Clean the seat area as outlined in Routine Seat Cleaning.
	Damaged seat face or seat O-Ring	Inject seat sealant for temporary seal or replace seats
	Valve not fully closed	Check that operator or limit-switches do not stop the rotation of ball prior to reaching the fully closed position.
	Valve stops incorrectly set	Adjust stops on actuator
Gear operator hard to operate or stuck	Water in gear	Drain water and lubricate if possible. Replace weather seal if applicable.
Pneumatic operators excessive chatter during operation	Low air flow	Increase air flow and operation speed
	Dried operator seals	Lubricate operator cylinder and seals with approved lubricant
	Restriction in vent	Clear restriction
	Actuator was undersized for service conditions	Check torque requirements of valve for service conditions
	Service conditions require routine maintenance and/or lubrication	Refer to operator maintenance manual



Contact your Cameron's Valves & Measurement group representative for a Repair Manual

**WKM<sup>®</sup>**



**3250 Briarpark Drive, Suite 300  
Houston, Texas 77042  
USA Toll Free 800 323 9160**

For the most current contact and location information go to: [www.c-a-m.com/valvesandmeasurement](http://www.c-a-m.com/valvesandmeasurement)

© Cameron's Valves & Measurement Group Revised 11/07 WKM-370D4-IOM