

TOM WHEATLEY™ Swing Check Valves

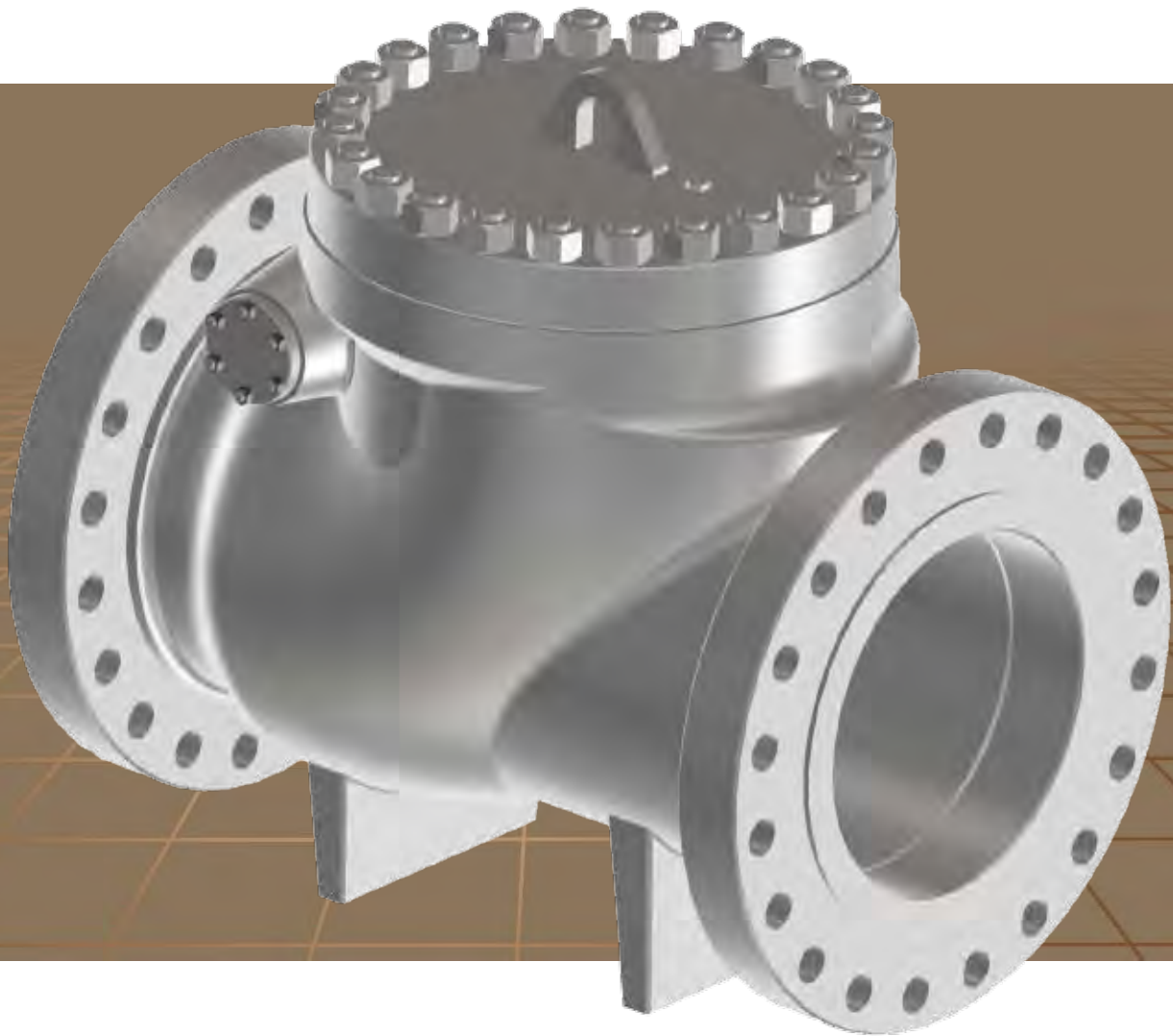

TOM WHEATLEY™

TABLE OF CONTENTS

TOM WHEATLEY SWING CHECK VALVES

Introduction.....	3
Technical Overview	4
Applications.....	4
Dimensions and Weights.....	5
Design Features	6
Optional Features.....	10
Special Features	13
Available Trims.....	14
ANSI Class 150	15
ANSI Class 300	16
ANSI Class 600	17
ANSI Class 900	18
ANSI Class 1500	19
How to Order	20
Quality Assurance	21
Aftermarket Services	22
Trademark Information	23



Ville Platte, LA

Cameron's Valves & Measurement (V&M) group is a leading provider of valves and measurement systems to the Oil and Gas industry. The group's products are primarily used to control, direct and measure the flow of oil and gas as it is moved from individual wellheads through flow lines, gathering lines and transmission systems to refineries, petrochemical plants and industrial centers for processing.

The Engineered and Process Valves division provides a wide range of valves for use in natural gas, LNG, crude oil and refined products transmission lines. The traditional CAMERON® fully-welded ball valve product line has been combined with the GROVE®, RING-O®, TOM WHEATLEY®, ENTECH™ and TK® product lines. This broad offering has significantly strengthened Cameron's ability to serve as a single source for a wide scope of customer requirements. The division also provides critical service valves for refinery, chemical and petrochemical processing businesses and for associated storage terminal applications, particularly through the ORBIT® and GENERAL VALVE®. These brands are complimented by WKM® and TBV™ valve products and considerably expand the scope of this division's product offerings.

TOM WHEATLEY check valves have been an integral part of the subsea and surface flow control arenas for over 70 years. With valves in service around the world, in the most critical backflow prevention applications, TOM WHEATLEY is recognized as the industry leader for check valve products. From deep water subsea check valves designed to protect offshore platforms, to the fire resistant valves used in surface pipeline and processing applications, TOM WHEATLEY offers a complete line of swing, piston and nozzle check products to meet our customers' most demanding applications.

TOM WHEATLEY™ SWING CHECK VALVES

TECHNICAL OVERVIEW

- Check valves are used primarily in oil and gas pipelines where backflow is to be prevented
- Check valves can be utilized in surface and subsea manifold production systems, or where a pipeline requires isolation
- The valves are available in a wide range of materials to suit various pressures, temperatures and service conditions encountered in the industries that are served
- From extreme temperature and pressure to subsea service, valves are available in virtually any size, pressure class, material, trim and design configuration to handle the industry's most demanding applications

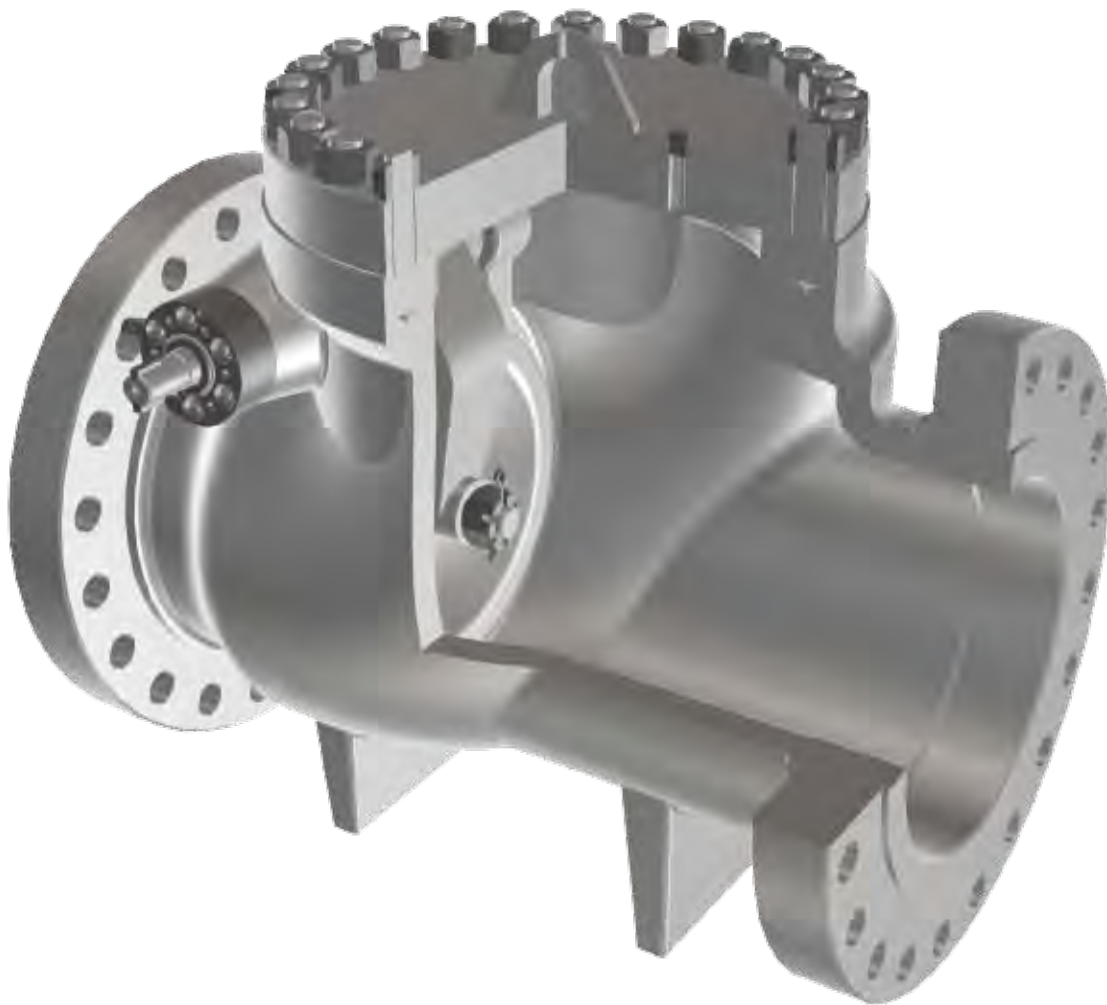

APPLICATIONS

TOM WHEATLEY swing check valves are commonly used by the hydrocarbon industry to:

- Prevent backflow in pipelines
- Prevent leakage to the environment in the event of a pipeline rupture
- Protect the integrity of upstream equipment

TOM WHEATLEY™ SWING CHECK VALVES

DIMENSIONS AND WEIGHTS 6 IN. - 48 IN. (50 MM - 1200 MM)

The majority of valve sizes detailed in this section can be engineered to accept the optional features detailed in this brochure. Sizes, pressure classes and end connections – not listed are available upon request.

Sizes and Pressure Classes Available

SIZE		ASME CLASS					
in.	(mm)	150	300	600	900	1500	2500
6	(150)	●	●	●	●	●	●
8	(200)	●	●	●	●	●	●
10	(250)	●	●	●	●	●	●
12	(300)	●	●	●	●	●	●
14	(350)	●	●	●	●	●	●
16	(400)	●	●	●	●	●	●
18	(450)	●	●	●	●	●	↓
20	(500)	●	●	●	●	●	↓
22	(550)	●	●	●	●	●	↓
24	(600)	●	●	●	●	●	↓
26	(650)	●	●	●	●	●	↓
28	(700)	●	●	●	●	●	↓
30	(750)	●	●	●	●	●	↓
36	(900)	●	●	●	●	↓	↓
42	(1050)	●	●	●	↓	↓	↓
48	(1200)	●	●	●	↓	↓	↓

↓ Other sizes available upon request.

TOM WHEATLEY™ SWING CHECK VALVES

DESIGN FEATURES

The secret of the TOM WHEATLEY swing check valve success is simplicity. Without expensive actuation or reliance upon an outside power source, a TOM WHEATLEY swing check valve prevents backflow in a fraction of a second. The clapper is the only moving part which swings to allow flow. At the moment flow ceases, the clapper returns to the closed position, creating an instant barrier to reverse flow. It is simple and effective.

In addition, a swing check valve is easy to troubleshoot and easy to maintain with convenient top entry access to all valve internals.

The design of the valve complies with the requirements of API Spec 6D 1st. Edition, February 1995, reaffirmed September 2008 / ISO 14313, ANSI 16.34 and API 6D SS / ISO 14723. Unless otherwise agreed with the customer, materials of construction are selected to comply with the requirement of these standards and NACE MR0175 / ISO 15156.

In its standard configuration these valves have a bolted cover and a free swinging clapper. The clapper is the closing member that responds to the prevailing flow conditions.

All valves are full bore, full conduit design and will allow the passage of various pipeline inspection gauges and spheres. The full bore design ensures a low pressure drop across the valve and less turbulence than with reduced bore valves or alternative designs of swing check valves.

The valve ends are available to meet any pipeline requirement. The valves are supplied with raised face, ring type joint flanges or weld ends. Raised face and ring type joint flanges comply with the requirements of ASME B16.5 and ASME B16.47 as appropriate.

Flanges are backfaced to provide a smooth bolting surface to allow even bolt loading during installation in the pipeline.

Weld end valves comply with ASME B16.25 unless otherwise agreed with the customer. Hub ends and other specialty end connections are available upon request.

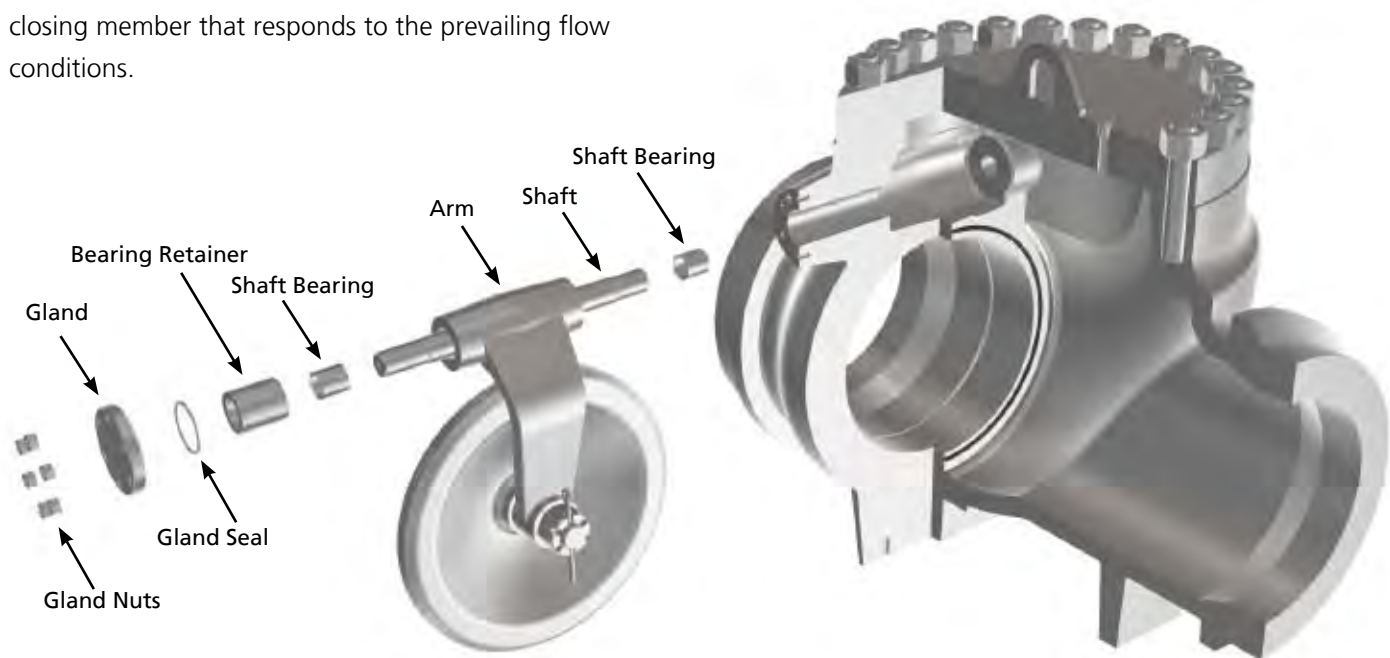

TOM WHEATLEY™ SWING CHECK VALVES

DESIGN FEATURES

Seat Options

TOM WHEATLEY swing check valves are available with either an integral seat or a renewable seat. A renewable seat extends the life of the valve by allowing all internal parts and seals to be replaced with the valve body still installed in the pipeline.

Sealing materials are selected for the valve service conditions. Pressure, temperature and flow media are all considered when selecting seals. Standard seal materials

include Fluoroelastomer and Nitrile for the seat to clapper seal. Standard cover seal materials are Nitrile and Fluoroelastomer but, ring joint gaskets can also be used for the cover to body seal.

TOM WHEATLEY valves are available with an extended operating shaft to allow the valve to be locked in the open position for pigging or testing purposes, or to mount a rotary damper for pulsating gas flow service.

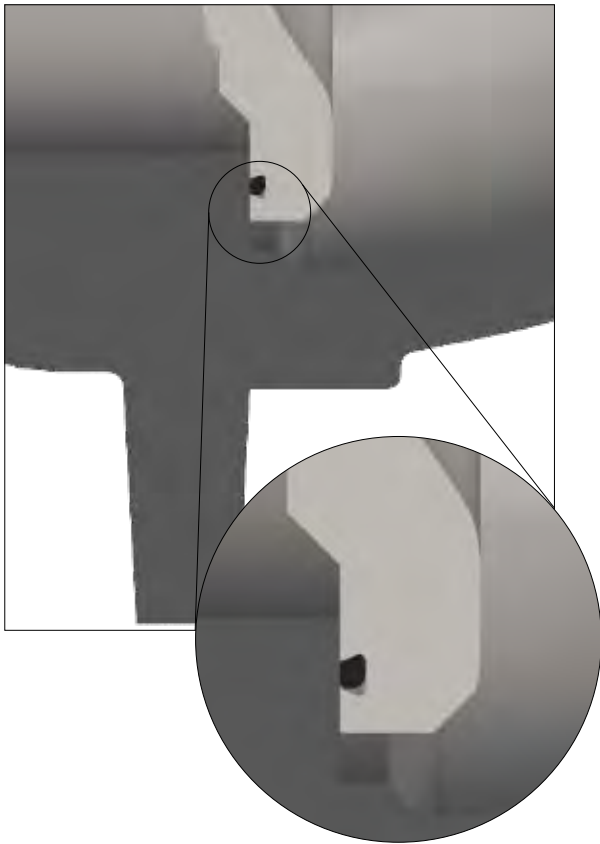

The TOM WHEATLEY swing check valve features a seat that is integral with the standard body. As an option, a renewable seat is field serviceable and facilitates the use of corrosion resistant steels, overlays, and seat styles. Renewable seats are securely mounted inside the valve body using fasteners.

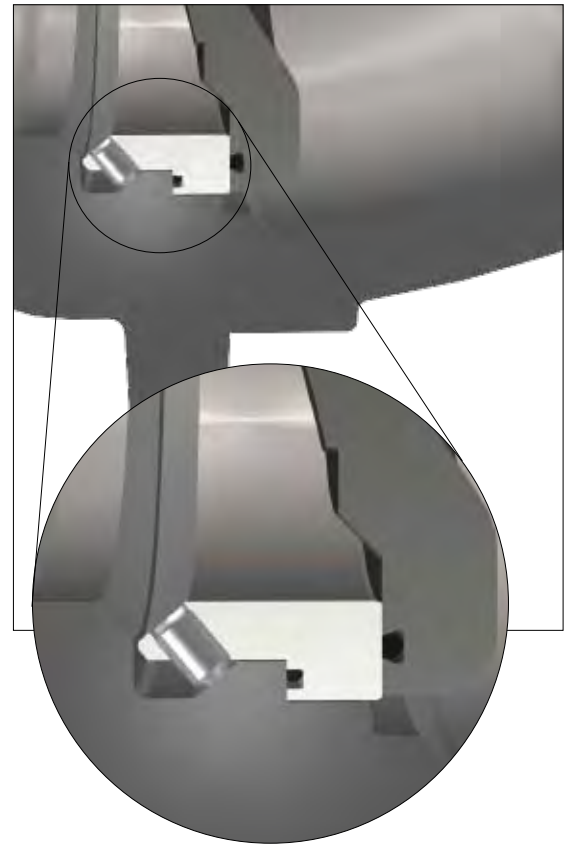

The renewable seat option allows the repair or replacement of all the seat sealing elements in the valve. By having both the seat and clapper as separate parts from the body, a damaged valve can be restored to as-new condition and performance. A renewable seat also facilitates use of different corrosion resistant materials and modified seat designs to accommodate pipeline pigs.

TOM WHEATLEY™ SWING CHECK VALVES

DESIGN FEATURES

Clapper Construction

The clapper is a one piece cast design that is mounted to the valve clapper-arm with a secure and positively located fastener.



45 Degree Seat

In addition to the conduit clapper, another aid in successful pigging operations, especially in the reverse direction, is the 45 degree seat. The seat ring and clapper seat faces are profiled at a 45 degree angle to assist as pipeline pigs transition through the valve body. Changes in profile at the seat area that could potentially catch the edge of a pig and damage instruments are minimized.



Conduit Clapper

The TOM WHEATLEY check valve is designed to facilitate pigging operations and to protect instrumentation on intelligent pigs. A "conduit clapper" profile that closely matches the valve bore helps to guide the pig through the body of the valve and into the downstream pipe.



The TOM WHEATLEY swing check valve clapper has been designed using the latest Finite Element Analysis (FEA) and Computational Flow Dynamics (CFD) techniques to create a sealing barrier that is strong while at the same time allows maximum flow with minimum pressure drop through the valve. As a standard, the clapper contains an elastomer seal to create a zero leakage seal against the seat. Polymer seals are optional. The clapper face can also be overlaid with corrosion resistant alloys or hard facing for metal to metal sealing applications and / or corrosion resistance.

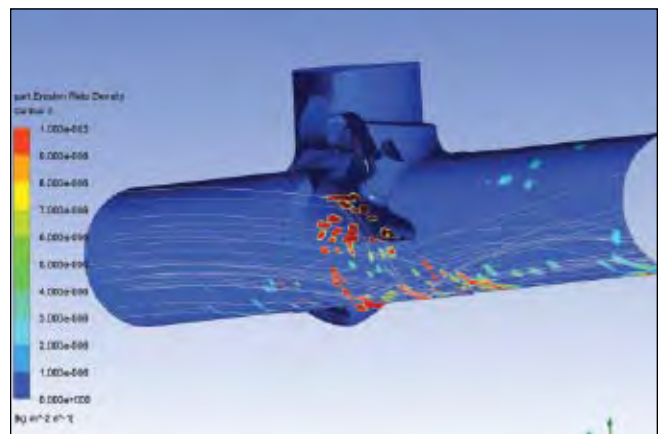

TOM WHEATLEY™ SWING CHECK VALVES

DESIGN FEATURES

Gland and Seals

The standard gland is a bolted-on shaft cover with an elastomer seal. The gland bolting pattern is standardized for all gland types to allow multiple gland and shaft seal configurations without machining the body. Polymer seals are optional.



Bearings for Shaft

Stainless steel bearings backed with PTFE are located on both ends of the valve shaft to support the arm and clapper for smooth, low friction movement of the clapper.

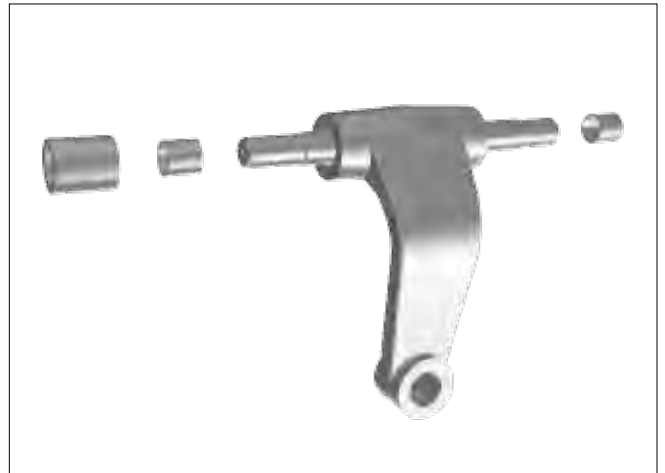

Cover Seals

An elastomer seal is the standard seal. Metal seals are optional and available in various materials options. The cover and bolting pattern are standard regardless of type of cover seal.

Body Bolting

As a standard, all bolting meets ASME B16.34 and ASME VIII Div. 1 design requirements.

TOM WHEATLEY™ SWING CHECK VALVES

OPTIONAL FEATURES

Gland Designs

S1 Gland

The S1 gland is the standard gland for extended shaft configurations. It features a bolted on gland body with two elastomer shaft seals and an elastomer body seal. Lubricant / sealant injection is standard between the primary and secondary shaft seals. Polymer seals are available as an option.

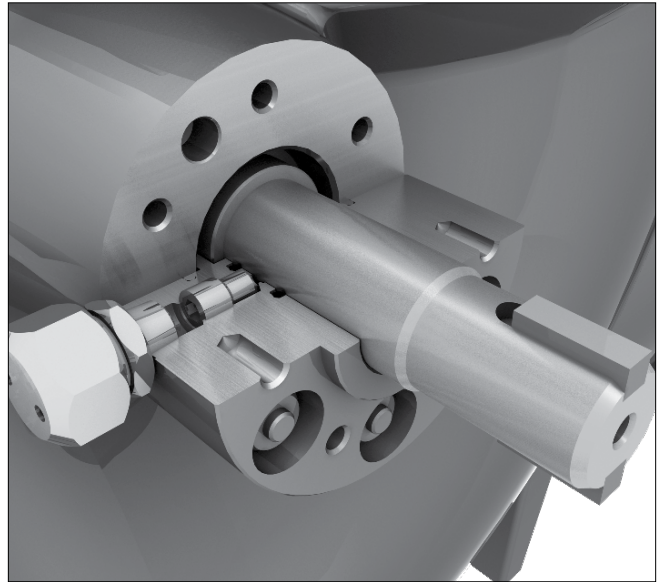

S2 Gland

The S2 gland is an optional gland for extended shaft applications. It features two spring energized lipseals for shaft seals and an elastomer body seal. Lubricant/sealant injection is also a standard feature on this gland. For 6" through 16" valves, the secondary lipseal is retained by a threaded gland retainer. For valves 20" and larger, the secondary lipseal is retained by the gland flange. In both cases, the secondary lipseal is field replaceable.

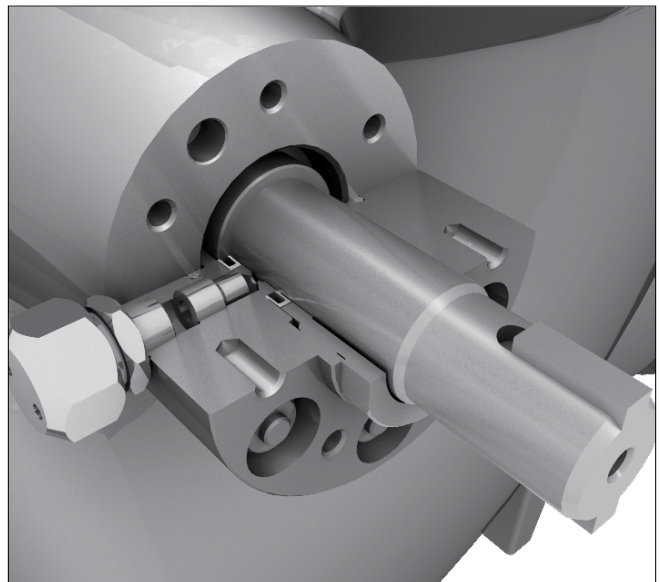

TOM WHEATLEY™ SWING CHECK VALVES

OPTIONAL FEATURES

Subsea T1 Gland

The T1 gland is used for subsea service, and features spring energized polymer lipseals for the dynamic shaft seals and double barrier elastomer seals for the gland body seals. The gland contains an outward facing lipseal that prevents ingress of seawater into the valve. The gland flange seals against the gland body and the gear operator to prevent seawater ingress. In the event of shaft seal leakage, the gear operator is protected from internal pressure by means of a pressure relief fitting installed in the gland flange.

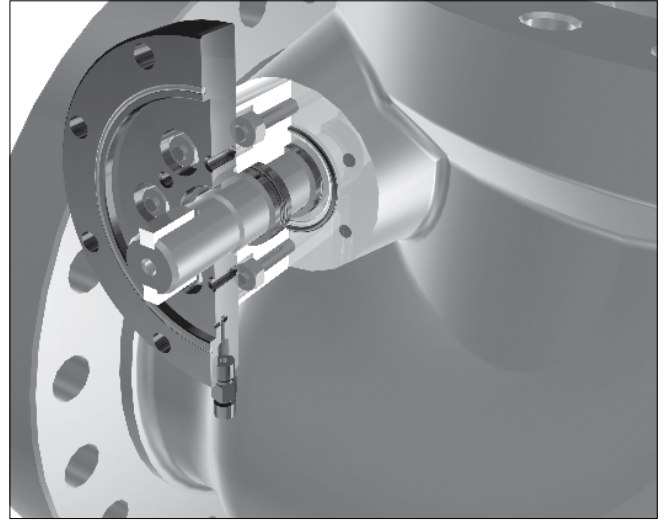

Shaft Cover

An optional shaft cover is available that can bolt directly to the extended shaft gland, or flange to protect the shaft when it is not in use. The shaft cover is designed to contain the valve's full rated working pressure and to prevent leaks to the environment.

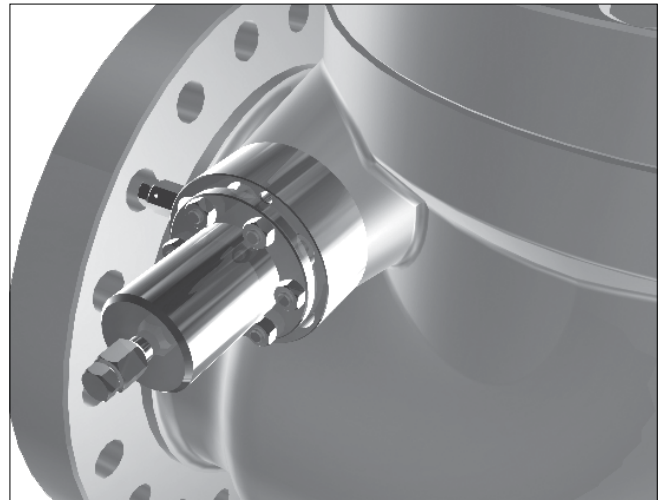

TOM WHEATLEY™ SWING CHECK VALVES

OPTIONAL FEATURES

Lock Open Device

The lock open device allows easy opening of the check valve clapper and locks the clapper in the full open position. The lock open device is intended for applications requiring the override of the normal check valve function. These applications may include locking open for testing, line drainage, reverse pigging or other reverse flow conditions. Valves 16" class 900 and smaller can be locked open using a manual lever or a gear operator. Larger valves are supplied with a gear operator to lock open the valve as a standard. In either configuration, the lock open device will hold the valve in the open position for operating scenarios. The lock open feature requires that the valve have an extended shaft. The shaft seal gland can be either an S1 gland with elastomer seals or an S2 gland with lipseals.

Use of the lock open device requires equalized pressure (balanced pressure) across the closed clapper. Excess force applied to open the valve against differential pressure may damage the internal components of the valve.

A valve shaft cover is furnished with the valve for installation when the lock open device is not in use.

Rotary Retarder (Mini-Slam™)

The TOM WHEATLEY swing check valve can be furnished with a Mini-Slam II rotary dampener that is specifically designed for swing check valves. The dampener acts to reduce or dampen, the movement of the clapper in pulsating flow service such as directly downstream from a reciprocating compressor.

The Mini-Slam II is a self contained and compact unit that bolts directly to the valve shaft.

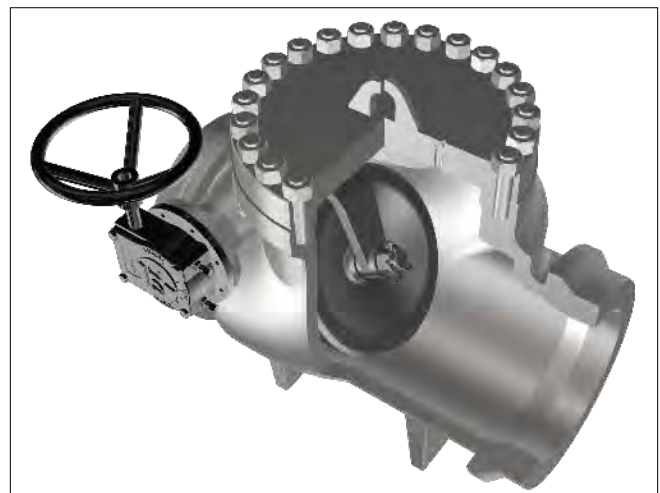

TOM WHEATLEY™ SWING CHECK VALVES

SPECIAL FEATURES

Testing

TOM WHEATLEY swing check valves are manufactured and tested per API Spec 6D / ISO 14313 as a standard. Every valve receives a hydrostatic body shell test at 1.5 times its rated working pressure and a hydrostatic seat test at 1.1 times its rated working pressure. Additional pressure testing is available including air and nitrogen testing.

High Pressure Gas

TOM WHEATLEY swing check valves can be tested using high pressure gas upon request. CAMERON is fully equipped to carry out supplemental gas testing at ambient, low or high temperatures using our in-house test facilities. External leakage rates (if any) are detected by means of a mass spectrometer. Leakage through the seats (if any) is measured by means of calibrated flow meters. For low or high temperature service, gas testing

can be performed to customer specified critical conditions. Cameron facilities are capable of testing a wide range of valve sizes and pressure classes.

Qualification Testing

Company Specific Test Programs. Fire tested to API 6FD 1st. Edition, February 1995, reaffirmed September 2008.

Materials – NACE Requirements

TOM WHEATLEY swing check valves are built to comply with the standards of NACE MR0175 / ISO 15156 as a standard.

Available Trims

Standard materials of construction are:



TOM WHEATLEY™ SWING CHECK VALVES

AVAILABLE TRIMS

Standard trims are shown below, however, higher materials and overlays area available to suit any service

Component	Standard Temperature Service	Low Temperature Service	Corrosion Resistant Service
	-20°F to +350°F Service	-50°F to +350°F Service	-20°F to +350°F Service
Component	Material		
Body	ASTM A216 WCC	ASTM A352 LCC	ASTM A216 WCC
Cover	ASTM A36	ASTM A516 Gr. 70†	ASTM A36
Clapper	ASTM A216 WCC	ASTM A352 LCC	ASTM A216 WCC with stainless overlay
Seat	ASTM A36‡	ASTM A516 Gr. 70	ASTM A36‡ with stainless overlay
Arm	ASTM A216 WCC	ASTM A352 LCC	ASTM A216 WCC
Shaft	316 Stainless*	316 Stainless*	316 Stainless*
Gland Body	ASTM A350 LF2	ASTM A350 LF2	ASTM A350 LF2
Bolting	ASTM A193 B7/A194 2H	ASTM A320 L7/A194 Gr. 7	ASTM A193 B7/A194 2H
Static Seals	Fluoroelastomer	Fluoroelastomer	Fluoroelastomer
Dynamic Seals	Fluoroelastomer or PTFE	Fluoroelastomer or PTFE	Fluoroelastomer or PTFE

Component	Subsea Service	Low Temperature Corrosion Resistant Service	Subsea Corrosion Resistant Service
	-20°F to +350°F Service	-50°F to +350°F Service	-20°F to +350°F Service
Component	Material		
Body	ASTM A216 WCC	ASTM A352 LCC	ASTM A216 WCC
Cover	ASTM A36	ASTM A516 Gr. 70†	ASTM A36
Clapper	ASTM A216 WCC	ASTM A352 LCC with Stainless Overlay	ASTM A216 WCC with Stainless Overlay
Seat	ASTM A36‡	ASTM A516 Gr. 70 with Stainless Overlay	ASTM A36 with Stainless Overlay
Arm	ASTM A216 WCC	ASTM A352 LCC	ASTM A216 WCC
Shaft	316 Stainless*	316 Stainless*	316 Stainless*
Gland Body	316 Stainless	ASTM A350 LF2	316 Stainless
Bolting	ASTM A193 B7/A194 2H (Fluorocoated)	ASTM A320 L7/A194 Gr. 7	ASTM A193 B7/A194 2H (Fluorocoated)
Static Seals	Fluoroelastomer	Fluoroelastomer	Fluoroelastomer
Dynamic Seals	PTFE	Fluoroelastomer or PTFE	PTFE

* 17-4PH material for extended shafts.

† ASTM A350LF2 material may be substitute for a A516 GR70.

‡ All seats size 16" and smaller are ASTM A516 GR70 only.

TOM WHEATLEY™ SWING CHECK VALVES

ANSI CLASS 150

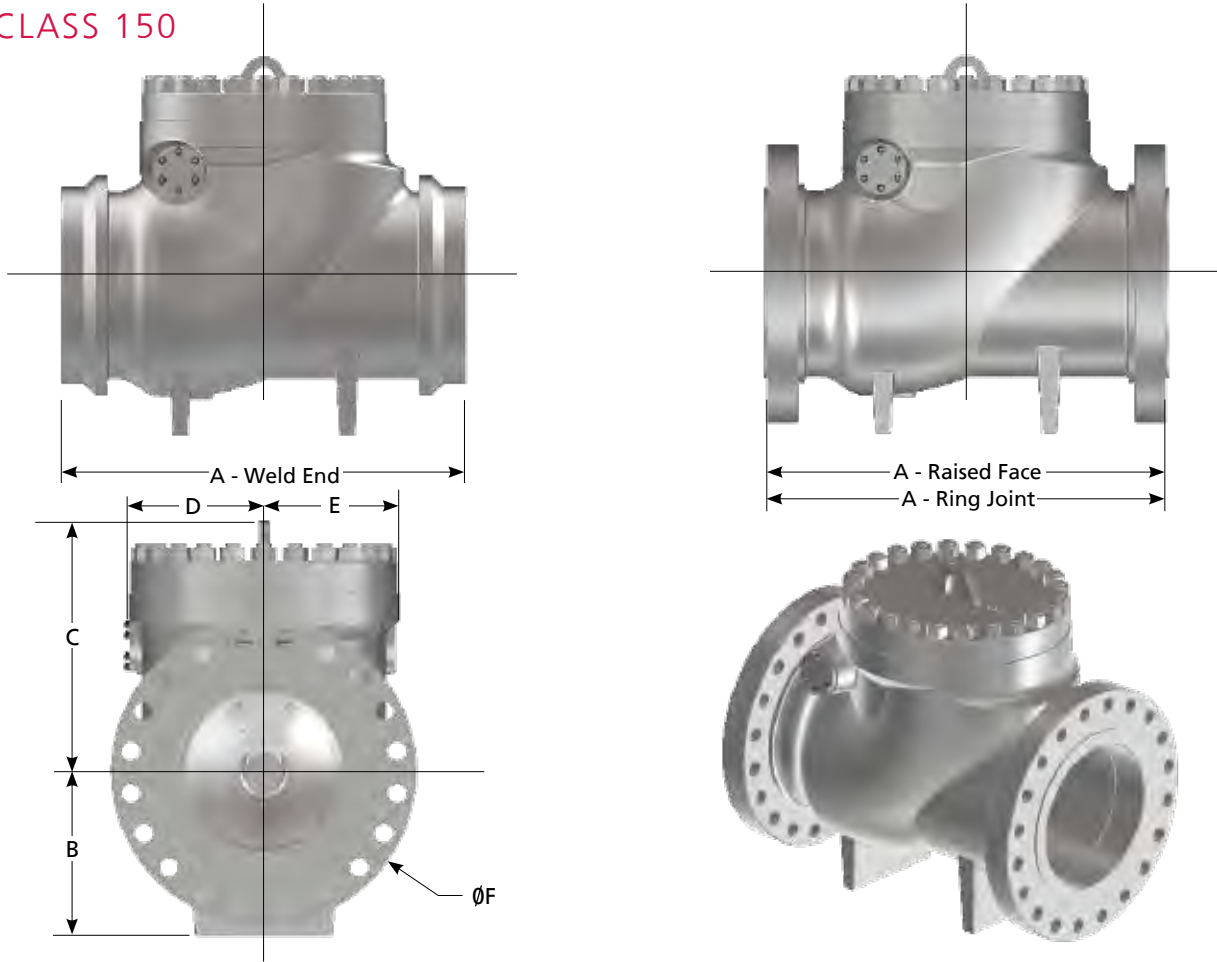

Size	WE - A in [mm]	RF - A in [mm]	RTJ - A in [mm]	B in [mm]	C in [mm]	D in [mm]	E in [mm]	F in [mm]	WE Weight lb [kg]	FE Weight lb [kg]
6	14.0 [356]	14.0 [356]	14.5 [368]	7.25 [184.2]	12.25 [311.2]	6.50 [165.1]	6.00 [152.4]	12.50 [317.5]	270 [122.5]	297 [134.7]
8	19.5 [495]	19.5 [495]	20.0 [508]	8.50 [215.9]	13.50 [342.9]	6.75 [171.5]	6.75 [171.5]	15.00 [381.0]	403 [182.8]	418 [189.6]
10	24.5 [622]	24.5 [622]	25.0 [635]	9.75 [247.7]	15.25 [387.4]	9.00 [228.6]	8.25 [209.6]	17.50 [444.5]	619 [280.8]	638 [289.4]
12	27.5 [699]	27.5 [699]	28.0 [711]	11.25 [285.8]	18.50 [469.9]	9.50 [241.3]	9.25 [235.0]	20.50 [520.7]	803 [364.2]	946 [429.1]
16	34.0 [864]	34.0 [864]	34.5 [876]	13.75 [349.3]	22.00 [558.8]	11.50 [292.1]	11.00 [279.4]	25.25 [641.4]	1540 [698.5]	1760 [798.3]
20	38.5 [978]	38.5 [978]	39.0 [991]	16.25 [412.8]	26.50 [673.1]	13.70 [348.0]	13.50 [342.9]	30.50 [774.7]	2310 [1047.8]	2640 [1197.5]
24	51.0 [1295]	51.0 [1295]	51.5 [1308]	19.00 [482.6]	32.00 [812.8]	18.75 [476.3]	18.75 [476.3]	36.00 [914.4]	3630 [1646.5]	4070 [1846.1]
30	60.0 [1524]	60.0 [1524]	SEE NOTE*	22.50 [571.5]	37.50 [952.5]	19.50 [495.3]	20.50 [520.7]	43.00 [1092.2]	6050 [2744.2]	7590 [3442.8]
36	77.0 [1956]	77.0 [1956]	SEE NOTE*	26.00 [660.4]	44.00 [1117.6]	22.50 [571.5]	23.50 [596.9]	50.00 [1270.0]	9130 [4141.3]	10340 [4690.2]

* Available upon request.

TOM WHEATLEY™ SWING CHECK VALVES

ANSI CLASS 300

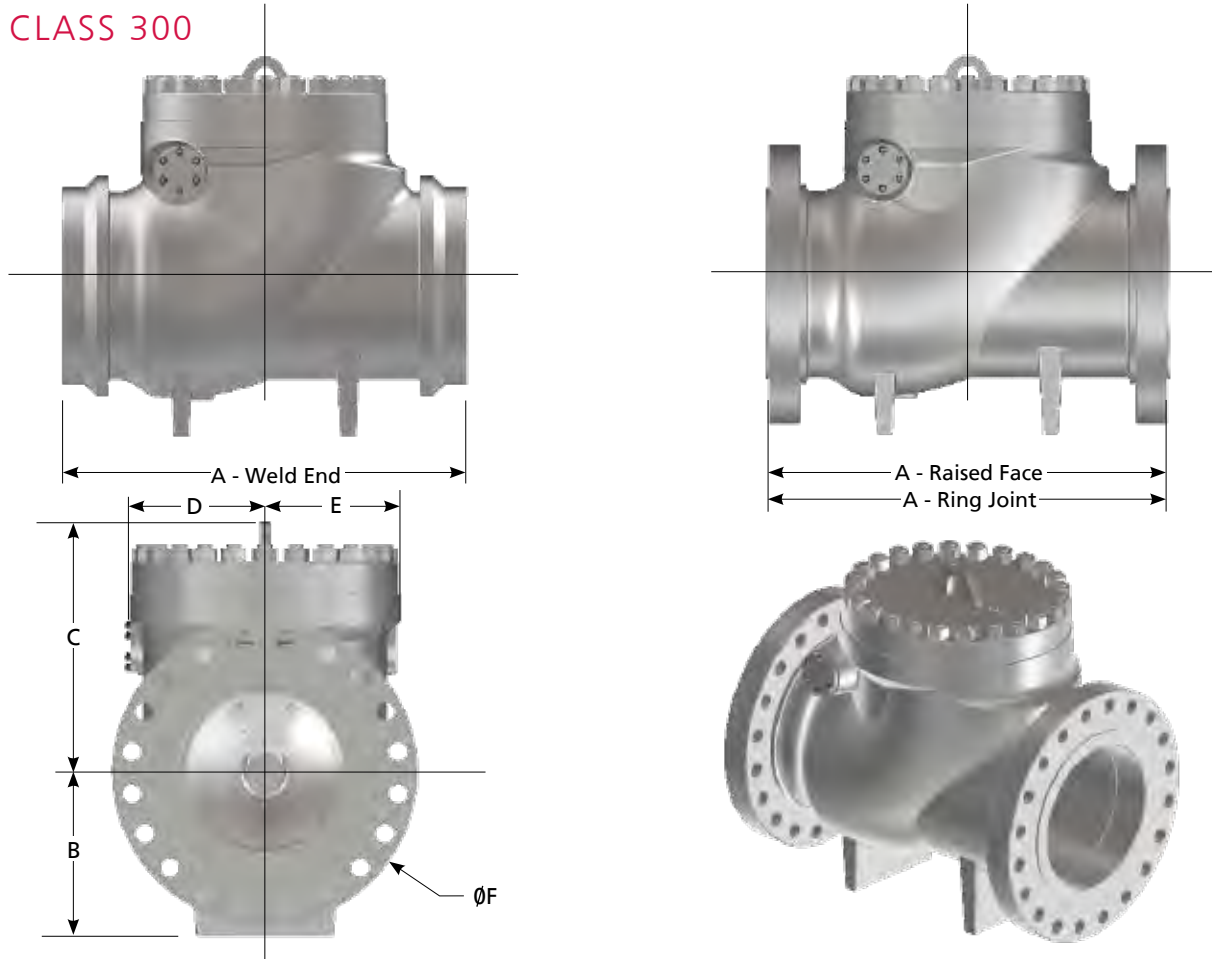

Size	WE - A in [mm]	RF - A in [mm]	RTJ - A in [mm]	B in mm	C in [mm]	D in [mm]	E in [mm]	F in [mm]	WE Weight lb [kg]	FE Weight lb [kg]
6	17.5 [445]	17.5 [445]	18.1 [460]	7.25 [184.2]	12.25 [311.2]	6.75 [171.5]	6.00 [152.4]	12.50 [317.5]	264 [120]	308 [139.7]
8	21.0 [533]	21.0 [533]	21.6 [549]	8.50 [215.9]	13.50 [342.9]	6.75 [171.5]	6.75 [171.5]	15.00 [381.0]	281 [127]	484 [219.5]
10	24.5 [622]	24.5 [622]	25.1 [638]	9.75 [247.7]	15.25 [387.4]	9.00 [228.6]	8.25 [209.6]	17.50 [444.5]	646 [293]	693 [314.3]
12	28.0 [711]	28.0 [711]	28.6 [727]	11.25 [285.8]	18.50 [469.9]	9.75 [247.7]	9.25 [235.0]	20.50 [520.7]	937 [425]	1001 [454.1]
16	34.0 [864]	34.0 [864]	34.6 [879]	13.75 [349.3]	22.00 [558.8]	11.50 [292.1]	11.00 [279.4]	25.25 [641.4]	1540 [698.5]	1760 [798.3]
20	40.0 [1016]	40.0 [1016]	40.8 [1035]	16.25 [412.8]	26.50 [673.1]	13.75 [349.3]	13.50 [342.9]	30.50 [774.7]	2640 [1197.5]	3080 [1397.1]
24	53.0 [1346]	53.0 [1346]	53.9 [1368]	19.00 [482.6]	32.00 [812.8]	18.75 [476.3]	18.75 [476.3]	36.00 [914.4]	4290 [1945.9]	4730 [2145.5]
30	62.8 [1594]	62.8 [1594]	63.7 [1619]	22.50 [571.5]	37.50 [952.5]	19.50 [495.3]	20.50 [520.7]	43.00 [1092.2]	7931 [3597.4]	8250 [3742.1]
36	82.0 [2083]	82.0 [2083]	SEE NOTE 1	26 [660.4]	44 [1117.6]	22.5 [571.5]	23.5 [596.9]	50 [1270.0]	13200 [5987.4]	14300 [6486.4]

TOM WHEATLEY™ SWING CHECK VALVES

ANSI CLASS 600

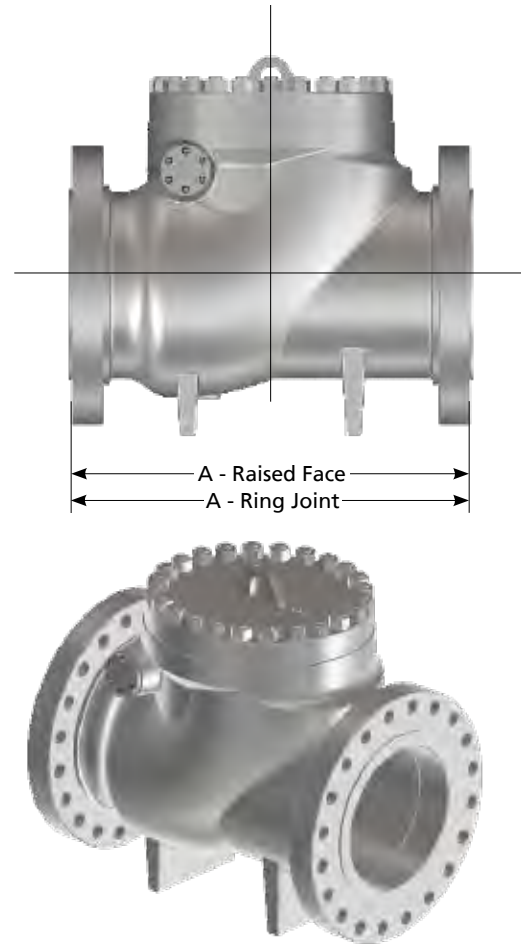
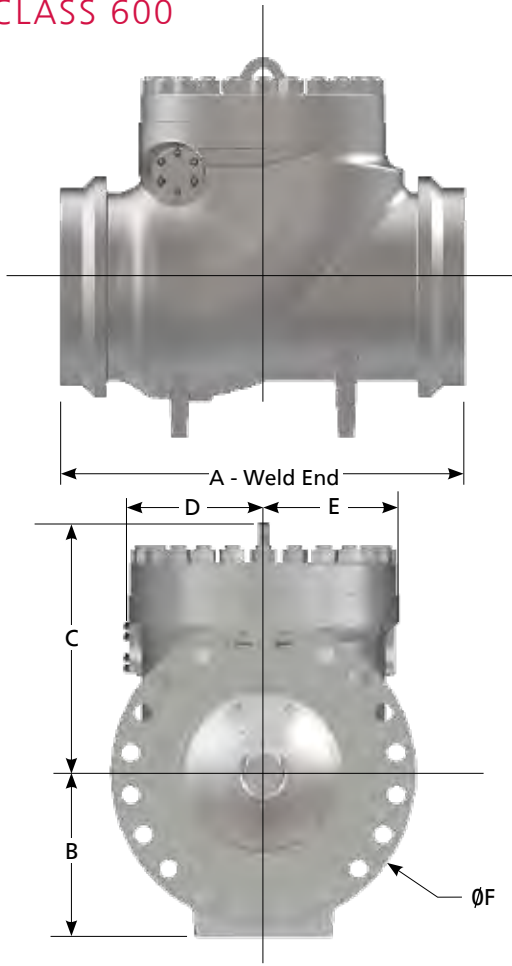

Size	WE - A in [mm]	RF - A in [mm]	RTJ - A in [mm]	B in [mm]	C in [mm]	D in [mm]	E in [mm]	F in [mm]	WE Weight lb [kg]	FE Weight lb [kg]
6	22.0 [559]	22.0 [559]	22.1 [562]	8.00 [203.2]	13.25 [336.6]	8.75 [222.3]	8.00 [203.2]	14.00 [355.6]	407 [185]	462 [210]
8	26.0 [660]	26.0 [660]	26.1 [664]	9.50 [241.3]	14.50 [368.3]	8.00 [203.2]	7.50 [190.5]	16.50 [419.1]	665 [302]	737 [334]
10	31.0 [787]	31.0 [787]	31.1 [791]	11.00 [279.4]	16.50 [419.1]	10.00 [254.0]	9.25 [235.0]	20.00 [508.0]	1097 [498]	1210 [549]
12	33.0 [838]	33.0 [838]	33.1 [841]	12.00 [304.8]	19.55 [496.6]	11.00 [279.4]	10.00 [254.0]	22.00 [558.8]	1421 [644.6]	1540 [698.5]
16	39.0 [991]	39.0 [991]	39.1 [994]	14.50 [368.3]	22.25 [565.2]	12.40 [315.0]	12.00 [304.8]	27.00 [685.8]	2420 [1098]	2640 [1198]
20	47.0 [1194]	47.0 [1194]	47.3 [1200]	17.00 [431.8]	28.50 [723.9]	15.00 [381.0]	15.00 [381.0]	32.00 [812.8]	3960 [1796]	4620 [2096]
24	55.0 [1397]	55.0 [1397]	55.4 [1407]	19.50 [495.3]	34.55 [877.6]	18.00 [457.2]	18.00 [457.2]	37.00 [939.8]	6270 [2844]	7260 [3293]
30	65.0 [1651]	65.0 [1651]	65.5 [1664]	23.50 [596.9]	39.00 [990.6]	21.50 [546.1]	23.00 [584.2]	44.50 [1130.3]	10560 [4790]	12100 [5489]
36	82.0 [2083]	82.0 [2083]	82.6 [2099]	27.50 [698.5]	48.25 [1225.6]	24.75 [628.7]	25.75 [654.1]	51.75 [1314.5]	18700 [8482]	20900 [9480]

TOM WHEATLEY™ SWING CHECK VALVES

ANSI CLASS 900

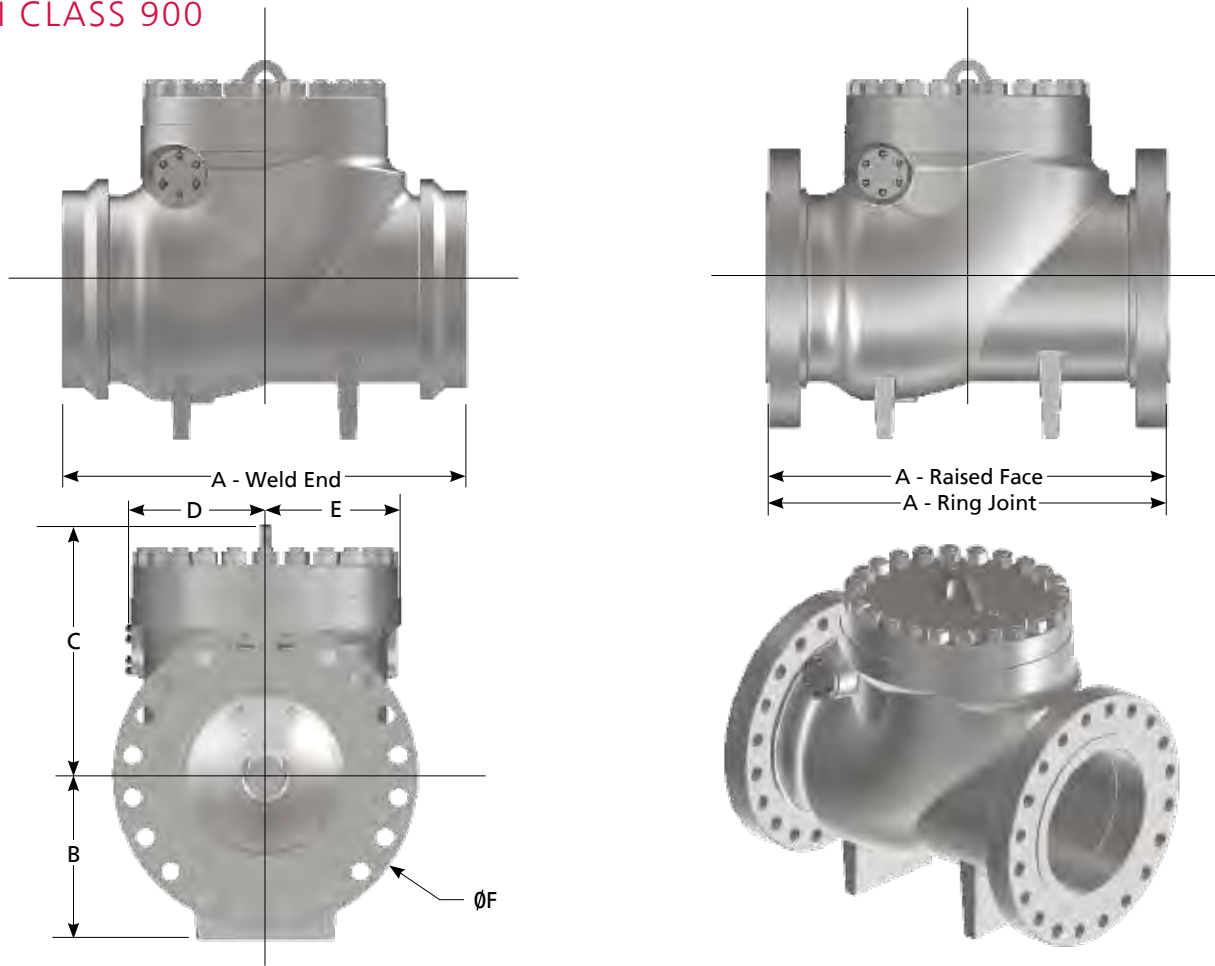

Size	WE - A in [mm]	RF - A in [mm]	RTJ - A in [mm]	B in [mm]	C in [mm]	D in [mm]	E in [mm]	F in [mm]	WE Weight lb [kg]	FE Weight lb [kg]
6	24.0 [610]	24.0 [610]	24.1 [613]	8.50 [215.9]	13.75 [349.3]	7.50 [190.5]	6.75 [171.5]	15.00 [381.0]	536 [243]	616 [279]
8	29.0 [737]	29.0 [737]	29.1 [740]	10.25 [260.4]	15.00 [381.0]	8.75 [222.3]	8.00 [203.2]	18.50 [469.9]	910 [413]	1034 [469]
10	33.0 [838]	33.0 [838]	33.1 [841]	11.75 [298.5]	17.50 [444.5]	10.75 [273.1]	10.00 [254.0]	21.50 [546.1]	1487 [674]	1650 [748]
12	38.0 [965]	38.0 [965]	38.1 [968]	13.00 [330.2]	20.75 [527.1]	11.75 [298.5]	10.75 [273.1]	24.00 [609.6]	1836 [832.8]	2200 [997.9]
16	44.5 [1130]	44.5 [1130]	44.9 [1140]	15.00 [381.0]	24.00 [609.6]	13.75 [349.3]	13.00 [330.2]	27.75 [704.9]	3300 [1497]	3740 [1696]
20	52.0 [1321]	52.0 [1321]	52.5 [1334]	18.00 [457.2]	30.00 [762.0]	15.75 [400.1]	16.00 [406.4]	33.75 [857.3]	5500 [2494]	6600 [2994]
24	61.0 [1549]	61.0 [1549]	61.8 [1568]	21.50 [546.1]	36.75 [933.5]	19.50 [495.3]	19.50 [495.3]	41.00 [1041.4]	9350 [4241]	12100 [5488]
30	74.5 [1892]	74.5 [1892]	74.9 [1902]	25.25 [641.4]	43.00 [1092.2]	23.75 [603.3]	23.25 [590.6]	48.50 [1231.9]	16500 [7484]	18700 [8482]
36	90.5 [2299]	90.5 [2299]	91.1 [2314]	30.00 [762.0]	50.00 [1270.0]	26.75 [679.5]	27.50 [698.5]	57.50 [1460.5]	26400 [11975]	31900 [14470]

TOM WHEATLEY™ SWING CHECK VALVES

ANSI CLASS 1500

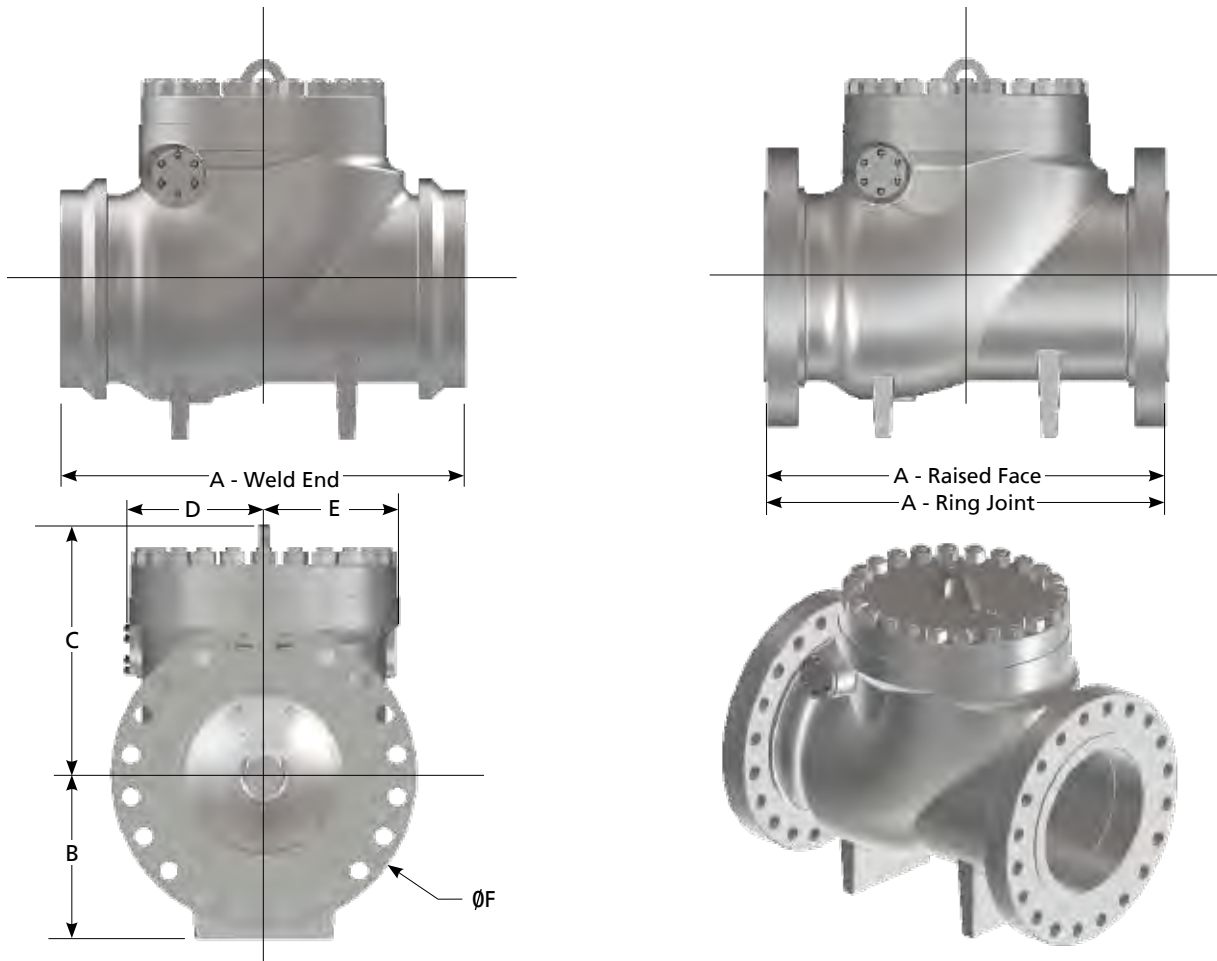

Size	WE - A in [mm]	RF - A in [mm]	RTJ - A in [mm]	B in [mm]	C in [mm]	D in [mm]	E in [mm]	F in [mm]	WE Weight lb [kg]	FE Weight lb [kg]
6	27.8 [705]	27.8 [705]	28.0 [711]	8.75 [222.3]	16.00 [406.4]	9.00 [228.6]	7.75 [196.9]	15.50 [393.7]	870 [394.6]	1001 [454.1]
8	32.8 [832]	32.8 [832]	33.1 [841]	10.50 [266.7]	17.75 [450.9]	10.00 [254.0]	9.00 [228.6]	19.00 [482.6]	1454 [659.5]	1650 [748.4]
10	39.0 [991]	39.0 [991]	39.4 [1000]	12.50 [317.5]	20.25 [514.4]	12.00 [304.8]	10.75 [273.1]	23.00 [584.2]	2093 [949.4]	2750 [1247.4]
12	44.5 [1130]	44.5 [1130]	45.1 [1146]	14.25 [362.0]	24.00 [609.6]	13.00 [330.2]	12.50 [317.5]	26.50 [673.1]	3571 [1619.8]	4070 [1846.1]
16	54.5 [1384]	54.5 [1384]	55.4 [1407]	17.25 [438.2]	27.00 [685.8]	16.00 [406.4]	15.00 [381.0]	32.50 [825.5]	5563 [2523.3]	7040 [3193.3]
20	65.5 [1664]	65.5 [1664]	66.4 [1686]	20.50 [520.7]	33.00 [838.2]	18.75 [476.3]	18.00 [457.2]	38.75 [984.3]	10099 [4580.8]	13200 [5987.4]
24	76.5 [1943]	76.5 [1943]	77.6 [1972]	24.00 [609.6]	41.25 [1047.8]	21.75 [552.5]	21.75 [552.5]	46.00 [1168.4]	16485 [7477.5]	20900 [9480.1]

TOM WHEATLEY™ SWING CHECK VALVES

HOW TO ORDER

Nominal Valve Size (V)	Pressure Class (P)	End Connection (E)	Material Selection (M)	Special Features (S)	Other Options (X)
6"	1 = 150	1 = RTJ x RTJ	1 = Carbon Steel Standard Temp 2 = Carbon Steel Low Temp 3 = Carbon Steel with 316 Stainless Overlay on Clapper/Seat Face 4 = Carbon Steel Low Temp w/316 Overlay on Clapper/Seat Face 5 = Carbon Steel with 316 Stainless Overlay in All Seal Areas 6 = Carbon Steel Low Temp w/316 Overlay in All Seal Areas 7 = All Stainless Steel 0 = Special	1 = Standard (Non-Extended Shaft)	SEAT (List 1st) 1 = Integral 2 = Renewable 3 = 45° Seat / Clapper 0 = Special
8"	3 = 300	2 = RF x RF		2 = Lock Open Feature with Wrench (6"-16")	GLANDS SEALS (List 2nd) 1 = O-Ring 2 = Lip Seal (Available for all "Special Features" Options Except #1*) 0 = Special
10"	6 = 600	3 = WE x WE		3 = Lock Open Feature with Gear Operator	COVER SEAL (List 3rd) 1 = O-Ring 2 = Ring Gasket 0 = Special
12"	9 = 900	0 = Special		4 = Dampener	CLAPPER (List 4th) 1 = Standard 2 = Conduit 3 = Metal to Metal 0 = Special
14"	5 = 1500			5 = Subsea Service	
16"	0 = Special			0 = Special	
18"					
20"					
22"					
24"					
26"					
28"					
30"					
32"					
34"					
36"					
38"					
40"					
42"					
48"					
0 = Special					

* If #5 is selected for "Special Features" Then #2 for "Gland Seals" should be selected as this is the only option when requesting "Subsea" for "Special Features"

Examples of Part Number Ordering:

V16-P6-E1-M1-S5-X1211 = 16", Class 600, RTJ x RTJ, Carbon Steel Standard Temperature, Subsea Service, Integral Seat, Lip Seal Gland Seals, O-Ring Cover Seals, Standard Clapper.

TOM WHEATLEY™ SWING CHECK VALVES

QUALITY ASSURANCE

Cameron's quality program is based on ISO 9000 and API Q1 codes. All valves are designed in accordance with the most stringent industry procedures and standards and are built according to the European Directive PED and ATEX upon request. The Quality Department monitors and controls all phases of valve production, inspection, and testing.

Cameron uses web based standardization tools, standardized supplier qualification processes, site based product validations, and performance metrics to maintain compliance to quality requirements. Cameron applies this quality strategy to its factories globally. Our main goal is to do it right the first time to achieve the best customer satisfaction.

Certifications

Cameron is ISO 9000 and API Q1 certified.

Licenses

Cameron holds API-6D, API 6D SS, ATEX, PED 97/23/EC (CE), GOST-R and CRN.
Auditing / Inspections.

Testing

All valves are tested per API Spec 6D 1st. Edition, February 1995, reaffirmed September 2008 / ISO 14313 and API-598.

AFTERMARKET SERVICES



Cameron's Aftermarket Services' goal is to help our customers lower the total cost of valve ownership. To that end we offer a full range of services from over twenty-five service centers worldwide and can provide experienced personnel trained to meet the specific service requirements of each valve type.

Aftermarket Services

- Supplies replacement valves and parts:
 - Maintains a full inventory of new and reconditioned valves for immediate delivery
 - Provides factory warranty support for all Cameron OEM brands as well as service for most other valves
- Field Service & Technical Support
 - Field service technicians on call 24 hours a day 7 days a week to handle service issues wherever they arise
 - Provides equipment installation, field repairs, as well as track and perform scheduled maintenance
- Customer Property Repair
 - The Customer Property Repair program allows Cameron valve customers to store assets at our service centers throughout the world
 - Valves tracked in electronic database accessible through the Internet
- Remanufactured Products
 - Offers a broad range of API-compliant reconditioned equipment with fast delivery
- Total Valve Management
 - Supply and service automation and control packages
 - Assist with valve installation, commissioning and start-up



TRADEMARK INFORMATION

TOM WHEATLEY™ is a registered trademark which is owned by Cameron.

**VALVES & MEASUREMENT**

3250 Briarpark Drive, Suite 300
Houston, TX 77042
USA Toll 800 323 9160

For the most current contact and location information go to: www.c-a-m.com